



INSTRUCTION MANUAL

For Model 7298 Triaxial Microtron® Variable Capacitance Accelerometer

IM7298, Revision A (07-10-13)



General Overview

The Endevco® Model 7298 Triaxial Microtron® accelerometer is a rugged, variable capacitance (VC) accelerometer family designed to provide the high thermal stability and global accuracy that is typically required for the measurements of relatively low-level accelerations in aerospace and automotive environments. Typical applications require the measurement of whole body motion in three mutually orthogonal directions immediately following shock motion or in the presence of severe vibration inputs.

Each axis of the triaxial accelerometer utilizes a patented VC microelectromechanical (MEMS) sensing element with internal gas damping and integral overrange stops. The triaxial sensor arrangement is housed in a truly hermetic bolt-mount package featuring an integral Glenair® Mighty Mouse 800-013 series hermetic receptacle. When mated with a compatible mating plug the connector assembly is protected from water ingress, making the 7298 an ideal choice for permanent installations in hose-down locations.

Internal signal conditioning allows the 7298 to operate from an excitation voltage from 6 Vdc to 45 Vdc while providing a high level, low impedance output. For each axis, the single-ended output is DC coupled and varies linearly from 0.5 Vdc to 4.5 Vdc over the acceleration input range, where a 0g input corresponds to 2.5 Vdc. For operating in differential mode, a precision 2.5 Vdc reference voltage is available at the connector, providing a DC coupled ± 2 Vdc differential output.

As is the practice with all instrumentation, certain precautions, including ESD precautions, should be followed with check-out, mounting and recalibration of the 7298 triaxial accelerometer.

Materials Required

A mating cable assembly will be required to complete the installation of the 7298 triaxial accelerometer. The Endevco® Model 3907 Cable Assembly is the recommended mating cable assembly; it features a robust Teflon jacketed, six conductor cable with a high-reliability Glenair® Mighty Mouse series 800-018 connector and a dual-wall shrink tube strain relief designed for resistance to water ingress.

A customer built cable assembly could also be used with this triaxial accelerometer permitting a compatible Glenair® Mighty Mouse connector (series 800-006 thru 800-009) is selected. For reference, the Glenair® part number for the hermetic receptacle used on the 7298 triaxial accelerometer is 800-013-03Z16-7PN.

All other materials used in the mounting of the Model 7298 triaxial accelerometer are supplied with the unit in the shipping container. These materials include:

(1) Allen wrench for 4-40 screws	(Meggitt part no. EHM464)
(2) 4-40 x 3/4 inch Socket Head Cap Screws	(Meggitt part no. EH69)
(2) Size 4, Flat Washers	(Meggitt part no. EHW265)

Although an Allen wrench (hex key) is provided, it is recommended to use a torque wrench to ensure mounting screws are torqued to the recommended value of 8 to 10 lbf-in.

Check-out

Before installing the triaxial accelerometer, each axis should be checked to ensure no damage occurred during shipping or unpacking. A simple 2g turnover test can be conducted in each axis with minimal test equipment (dc power supply, millivolt voltmeter and test leads) to check the zero measurand output (ZMO) and sensitivity. The shape and receptacle location of the 7298 triaxial accelerometer makes it difficult to precisely orient the three axes for the 2g turnover test without the use of an additional test fixture. Since this test is being used as a general health check, a rough measurement of the sensitivity and ZMO should be sufficient to ensure the accelerometer has not been damaged. If desired, consult the factory for the availability of an optional test fixture that would permit a more precise measurement of the sensitivity and ZMO by providing proper orientation of the axes during test.

The procedure below assumes the use of the model 3907 cable assembly, if a customer supplied cable assembly is used the appropriate signal assignment must be determined.

1. Connect the 3907 mating cable assembly to the 7298 triaxial accelerometer.
2. Familiarize yourself with the signal assignment of the mating cable assembly.

<i>Signal Assignment</i>	<i>7298 Pin No.</i>	<i>3907 Cable Assembly</i>	<i>Alternate Cable Assembly</i>
+ Excitation	1	red	_____
- Excitation	2, 4	black	_____
+ X-Axis Output	3	green	_____
+ Y-Axis Output	7	white	_____
+ Z-Axis Output	6	white/red	_____
2.5 V Reference	5	white/green	_____

3. Familiarize yourself with the measurement coordinate system of the 7298 triaxial accelerometer. The axes orientation is marked on the body of the accelerometer, where the arrows indicate the positive direction for each axis. Refer to Figure 1 for an illustration of the various orientations needed during the three 2g turnover tests to be performed.

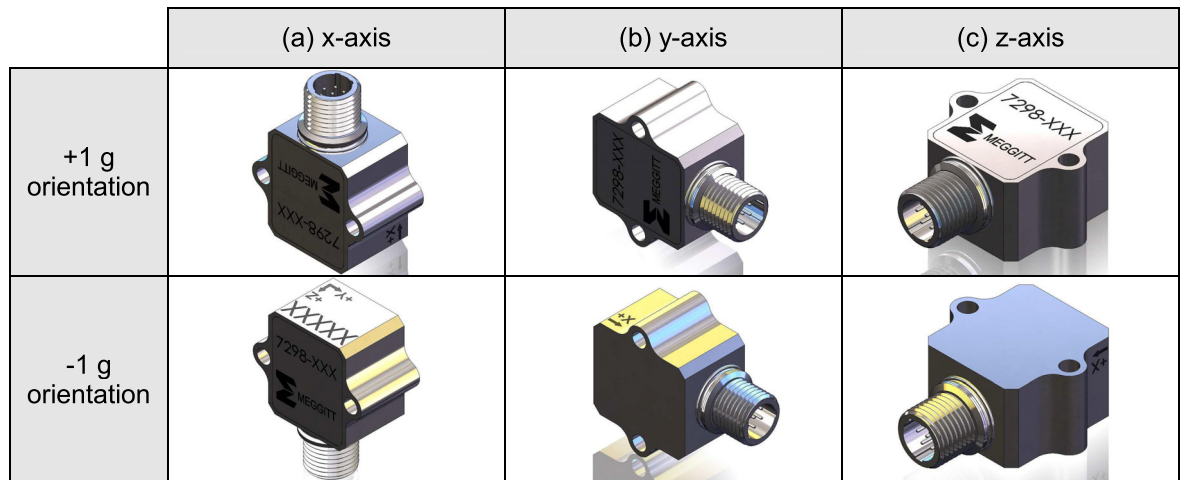

Figure 1. Orientations for 2g turnover testing of the (a) x-axis, (b) y-axis and (c) z-axis.

4. Apply an excitation voltage (6V to 45V) across the excitation leads (red and black) and allow the unit to warm up for two minutes.
5. For the x-axis test:
 - a. Orient the unit in the x-axis positive 1g position (per Fig. 1) and record the output voltage on the x-axis output lead (green) with reference to the 2.5V reference lead (white/green).
 - b. Orient the unit in the x-axis negative 1g position (per Fig. 1) and record the output voltage on the x-axis output lead (green) with reference to the 2.5V reference lead (white/green).
 - c. Calculate sensitivity by subtracting the negative 1g reading from the positive 1g reading and divide by two.
 - d. Calculate the ZMO by adding the negative 1g reading to the positive 1g reading and divide by two.
 - e. Compare sensitivity and ZMO measurements to the calibration certificate provided with the unit. Note: if a test fixture was not used to precisely orient the unit during the test, the measured results will not exactly match what is printed on the calibration certificate, this test would serve as a general health check only.
6. Repeat the test above for the y and z-axes, using the appropriate cable lead.
 - a. y-axis: measure between the y-axis output lead (white) with reference to the 2.5V reference lead (white/green).
 - b. z-axis: measure between the z-axis output lead (white/red) with reference to the 2.5V reference lead (white/green).

If this initial check does not give a proper reading, or if you have any questions about this test method, contact Meggitt (Orange County) Applications Engineering at +1-949-493-8181.

Mounting

When mounting the Model 7298 triaxial accelerometer, it is best to utilize the proper techniques and tools listed to ensure optimum performance.

1. Refer to Figure 2 for mounting surface preparation. The mounting surface should be clean and free of burrs. Two #4-40 threaded holes, 0.2 inch minimum depth should be spaced 0.825 inches (20.96 mm) apart. A 32 microinch rms surface finish with flatness of 0.0001 inches is recommended for the area that will contact the accelerometer. When planning the location of the threaded holes consider the mating cable assembly so that sufficient strain relief is provided without requiring too tight a bend radius. Also note that the location of the two holes, along with the direction on the mating cable assembly, will dictate the orientation of the measurement coordinate system.

Note: Even though screw mounting is preferred, adhesive mounting may be used if screw mounting is not possible. In determining the ideal adhesive for the specific application there are various factors to consider, such as the adhesion strength to the stainless steel case under the expected shock environment and the thermal mismatch of the case to the mounting surface (i.e. is a compliant adhesive required?).

If there are any questions relating to an application specific mounting requirement it is recommended to consult the factory. In general terms, for permanent installations Bacon Industries LCA-9 is recommended. If a compliant adhesive is required, Dow Corning 3145 RTV is recommended. For temporary installations a heat-sensitive wax (such as Crystalbond 509) or cyanoacrylate (super glue) may be used as long as the proper removal procedures are used to prevent damage to the triaxial accelerometer (such as using the proper solvent to soften the adhesive before removal). Under no circumstance should the accelerometer be pried free from the mounting surface.

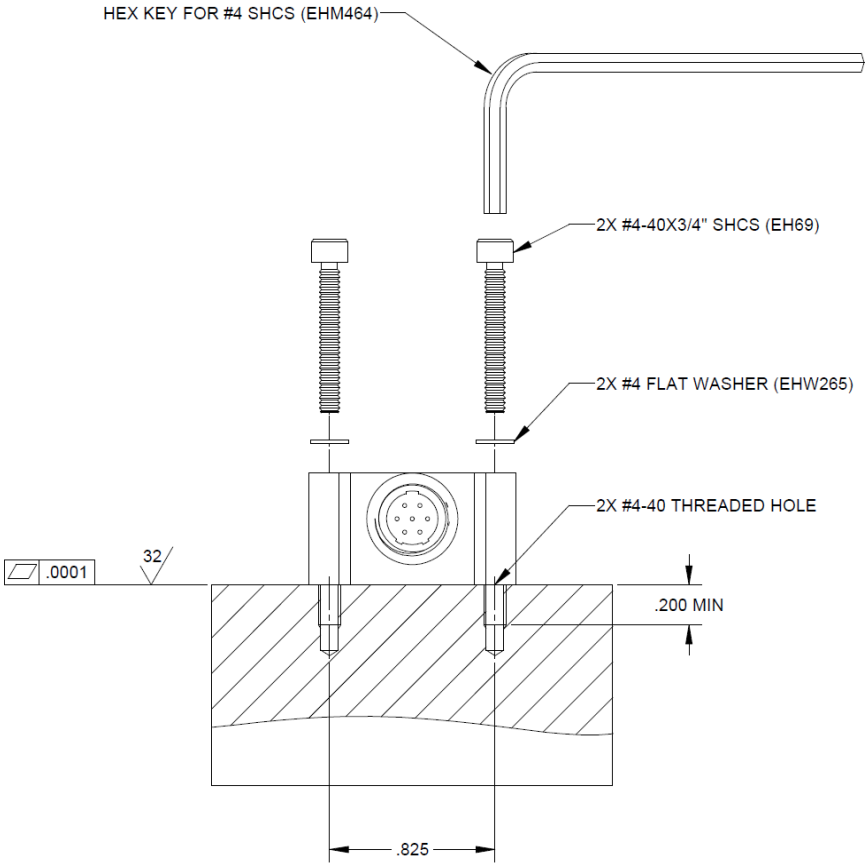

Figure 2. Installation of the model 7298 hermetic VC triaxial accelerometer.

2. Remove the unit from the shipping container. The unit will be clean straight out of the shipping box; if the mounting surface becomes unclean during handling it is recommended to clean the base of the unit with a clean cloth using acetone.
3. Place the unit on the mounting surface and align with the mounting holes.
4. Use the factory supplied mounting #4 screws and washers. If desired, metric size M3 screws (not supplied) may be used in place of the #4 screws. Slide the washers over the screws. Using the supplied hex key or a torque wrench, tighten the screws through the mounting hose to a torque of 8 to 10 lbf-in. Ensure the unit is mounted flat to the mounting surface as any deviations from flat will result in higher transverse sensitivity errors.

5. As practical, secure the cable to the mounting surface within 4 to 6 inches of the unit, allowing a slight strain relief loop in the cable. Whipping motion of the cable relative to the triaxial accelerometer during vibration and shock will strain the cable unnecessarily. As every installation is different, care should be taken to properly fix the cable to the mounting surface every 6 to 12 inches for the entire length of the cable run.
6. Connect the unit to the signal conditioner using the following lead designations:

<i>Signal Assignment</i>	<i>7298 Pin No.</i>	<i>3907 Cable Assembly</i>	<i>Alternate Cable Assembly</i>
+ Excitation	1	red	_____
- Excitation	2, 4	black	_____
+ X-Axis Output	3	green	_____
+ Y-Axis Output	7	white	_____
+ Z-Axis Output	6	white/red	_____
2.5 V Reference	5	white/green	_____

Electrical Precautions

1. Excitation – The model 7298 triaxial accelerometer has an internal voltage regulator that allows excitation voltages in the range of 6 to 45 Vdc, while maintaining a non-ratiometric (absolute) output. A low noise power supply is recommended and care should be taken to minimize pickup on the cabling to the accelerometer. The maximum current drain over the entire operating temperature range is 16 mA.
2. Signal Leads – For each axis, the single-ended output is DC coupled with an output that varies linearly with the input acceleration. For operating in differential mode, a precision 2.5 Vdc fixed reference voltage is available at the connector. Although the output is high level, the usual precautions of using twisted pair, shielded instrumentation cable should be taken to avoid noise pickup on the signal leads.
3. Grounding – The model 7298 triaxial accelerometer is case-isolated, meaning the outer case (including the mounting surface and receptacle shell) is electrically isolated from circuit ground. To ensure case-isolation is maintained, the shield of the model 3907 mating cable assembly is also isolated from the mating connector shell. If an alternate cable assembly is selected the cable shield should also be isolated from the mating connector shell. A single-point grounding scheme is recommended where the cable shield is only grounded at the power supply ground to avoid ground loops.
4. Signal Conditioning – For each axis of the 7298 triaxial accelerometer, the high level single-ended output is DC coupled and varies linearly from 0.5 Vdc to 4.5 Vdc over the acceleration input range, where a 0g input corresponds to 2.5 Vdc. For operating in differential mode, a precision 2.5 Vdc reference voltage is available at the connector. This allows a DC coupled ± 2 Vdc differential output, biased at 0g with a 0g reading (or ZMO) of 0 ± 50 mV.

With accelerations greater than approximately 1.2X full scale range the output of the overranged axis will electrically clip; the axis will begin to respond again as soon as the acceleration falls below $\sim 1.2X$ range, with a recovery time of < 10 μ seconds.

5. Loading Effects – The model 7298 triaxial accelerometer performs within specification limits while loaded with 10,000 Ω minimum resistance, and/or 0.1 μ F maximum capacitance.

Recalibration

Sensitivity and zero measurand output (ZMO) calibration should be performed at 6 to 12 month intervals, depending on usage. Ordinarily, recalibration should be performed at 12 month intervals if it is known that the accelerometer has not been used beyond its rated specifications. If the unit is used under severe environments, it may be desirable to use shorter calibration intervals.

Contact the Meggitt Sensing Systems Calibration Services Department for information on available calibration services or simply reference our website at www.endevco.com. Meggitt Sensing Systems maintains an accelerometer recalibration service with NIST traceability in the United States. Meggitt European Regional offices maintain accelerometer recalibration services with traceability to national standards.

Questions

If you have any questions regarding the use of this or any other Endevco® product, please contact Meggitt Sensing Systems Application Engineering at 1-800-982-6732 in North America, or your local sales representative.