

Model 2775C PE/IEPE Signal Conditioner
IM2775C

Instruction manual

Table of Contents

Table of Contents	2
1.0 Product Description	4
2.0 User Interface	5
2.1. Front Panel	5
2.2. Rear Panel.....	6
2.3. Internal (filter and integrator control)	7
3.0 Menu Interface	8
4.0 Standard Functions Menu.....	9
4.1. Mode	10
4.2. Sensor Type	10
4.3. T-Insert	10
4.4. FS Input Mode [EU]	11
4.5. Sensor Sensitivity [mV/EU, PC/EU].....	11
4.6. (Servo Output Scaling) [mV/EU]	11
4.7. Front End Filter	11
4.8. Output filter.....	12
4.9. Emulate 2775B	12
4.10. AC FSO (AC Full Scale Output) [V].....	13
4.11. Isolation	13
4.12. Excitation (Current) [mA]	13
5.0 Advanced Functions menu	14
5.1. LPF Switches	14
5.2. HPF Switches	14
5.3. Integ Switches	15
5.4. RS-232 Baud Rate	15
5.5. Unit Address	15
5.6. IP Address.....	15
5.7. Netmask	15
5.8. Gateway.....	15
5.9. Cal Constants K1-K16.....	16
5.10. Factory Restore	17
6.0 Web Interface	18
6.1. Mode Tab	18

6.2.	Sensor Tab	18
6.3.	Filters Tab	20
6.4.	Gains Tab	21
6.5.	Output Tab	22
6.6.	Remote Tab	23
6.7.	Settings page	24
7.0	Internal Switches	25
8.0	T-Junction Calibration	26
8.1.	Test Procedure	26
9.0	Safety	28
9.1.	Safety Considerations.....	28
9.2.	Definition of Terms and Symbols	28
9.3.	Ground the instrument	28
9.4.	ESD protection.....	28
9.5.	Do not substitute parts or modify the instrument	28
Appendix A: Using high temperature charge-mode accelerometers		30
Appendix B: RS-232 Remote Control Application Program Interface (API)		31

1.0 Product Description

The Endevco model 2775C is a high performance, benchtop PE/IEPE signal conditioner for use within environmental test laboratories, aerospace test cells, calibration systems, and general vibration laboratory testing applications. It is designed to accept inputs from IEPE transducers, piezoelectric transducers, and remote charge converters (RCCs), with a full scale input range from 0.01 to 100,000 engineering units (EU's) and a wide sensor sensitivity input range of 0.01 to 10,000 mV/EU and pC/EU, with a gain range of 0 to 10,000 and a frequency response bandwidth of 120 kHz (-3 dB corner).

The 2775C includes AC, DC, and servo outputs and operates from a regulated 12V DC, 12 W power source, with selectable ground isolation for cleaner data collection. With capability to install up to six units in an optional 19-inch rack accessory (model 4948A), the flexible setup of the model 2775C is accomplished either manually via the unit's front panel, or via the unit's integral Ethernet (10/100) or RS-232 interface. The unit also includes selectable input filtering (HP, LP, BP), selectable integration functions, and three status indicator LEDs for ISO Ground, Open/Short detected, and Output Overload.

Key features include:

- AC, DC and servo outputs
- PE, IEPE and RCC inputs
- Switchable isolation
- Gain range 0 to 10,000
- Wide frequency response, 120 kHz bandwidth, (-3dB corner)
- Input filtering: HP, LP, BP
- Wide full scale input range 0.01 to 100,000 EU
- Wide sensor sensitivity input range from 0.01 to 10 000 mV/EU, pC/EU

2.0 User Interface

2.1. Front Panel

The 2775C front panel provides user control to modify instrument settings. See Figure 1: Front panel.

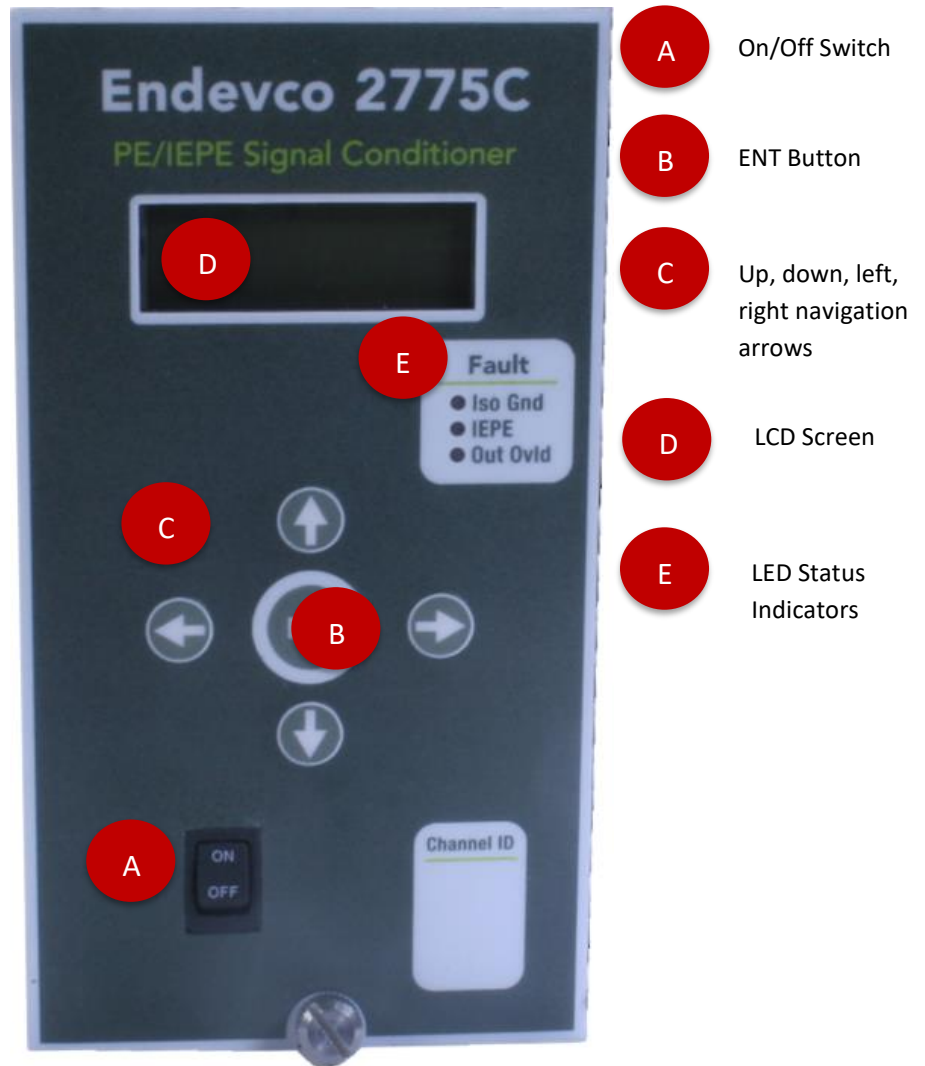

Figure 1: Front panel

In addition to controls, there are three fault indicators (red LEDs) located on the front panel.

- The Iso Gnd LED will turn on (red) for at least 1 sec. when operating in the isolated mode and the voltage between input common and the output common exceeds 6 VDC.
- The IEPE fault LED will turn on if the IEPE input is either open or short circuited while the input select function is set to IEPE.
- The Out Ovld LED will turn on when the Percent of Full Scale or DC output > 100% or 10 VDC

2.2. Rear Panel

Inputs (standard BNC connectors):

- Sensor
- ExtCal (External Calibration)

Outputs (standard BNC connectors):

- AC: Adjustable full-scale output from 0.001 to 10.000 Volts peak. Up to 40 mA available to drive large capacitive loads.
- DC: Fixed at 10 Volts DC full scale. An internal switch (see Figure 3: Filter and integrator switches) selects DC equivalent of the AC output (adjustable full-scale output from 0.001 to 10.000 Volts DC). This switch is identified, on the PC board, as SW13.
- SERVO: Selectable scaling of 0.1, 1.0, 10.0, 100.0, or 1000.0 mV/EU.

Remote control ports:

- Ethernet port – Instructions for the Web Interface via the Ethernet port is provided in this manual.
- RS-232 port - An RS-232 serial interface is available through an RJ-11 connector located on the rear panel. Endevco benchtop controller software 35933A is available as an optional accessory for the 2775C. See IM35933A for instructions on its use.



Figure 2: Rear panel

2.3. Internal (filter and integrator control)

The user can set low pass and high pass filter corner frequencies, as well as integration functions, by accessing switches inside the 2775C. Instructions for access are below. Detailed instructions on how to use the internal switches are found in Section 7.0.

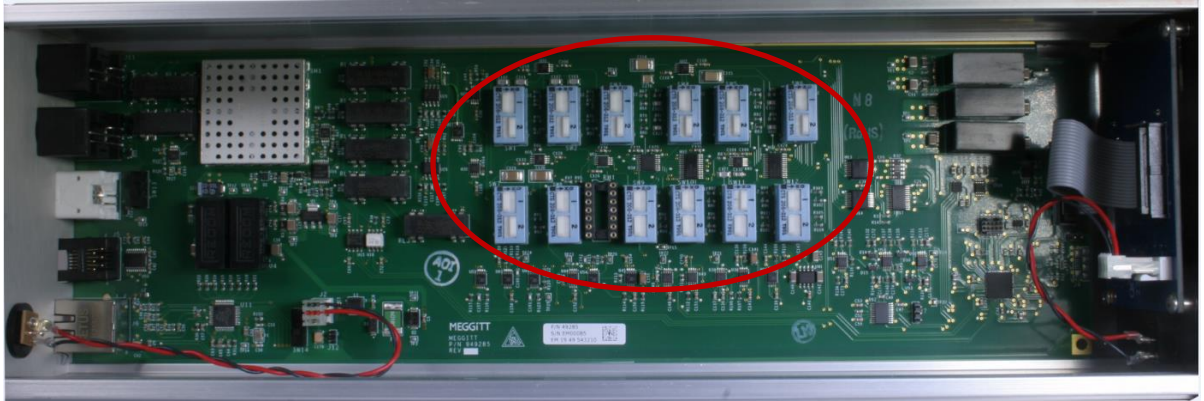

Figure 3: Filter and integrator switches



For internal switch access, remove this screw to allow side panel to slide back off unit

Figure 4: Side Panel Removal

3.0 Menu Interface

The 2775C is manually controlled from the front panel using the UP, DOWN, LEFT, RIGHT, and ENT push-buttons along with a two-row display of 16 characters per row.

The screen on the 2775C will display the current function selection centered on the top row. The bottom row displays the current value of the function.

For each function, there are two modes: “View” mode, and “Edit” mode. While in View mode, you can use the UP and DOWN buttons to scroll through the various functions of the 2775C. Using the UP and DOWN buttons in this way will place you in “View” mode for the other functions. When the unit is in View mode, an up and down arrow will be visible on the right side of the screen as illustrated in Figure 5: Input view mode.

To enter “Edit” mode for any function, press the ENT button. You will see that the up and down arrows on the right side of the screen disappear. Depending on the function, the bottom row will either be bookended with double-left angle brackets and double-right angle brackets, or a flashing cursor will appear. In addition, for all “Edit” modes, a carriage return symbol will appear in the top left corner of the screen. This symbol indicates that you can press ENT to return to the View screen of the current function.

Double angle brackets surrounding the bottom row (Figure 6: Input edit mode) indicate that the current Edit mode involves a discrete list of options. The list may be advanced in one direction using the UP or RIGHT buttons, and it may be advanced in the other direction using the DOWN or LEFT buttons. To change the value for this type of function, simply use UP, DOWN, LEFT, or RIGHT to scroll to the desired option, and press ENT. The 2775C will return to View mode for that function, and the bottom row will display the value for the function.

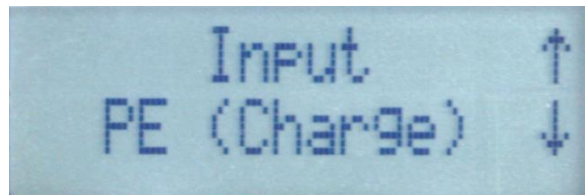

Figure 5: Input view mode

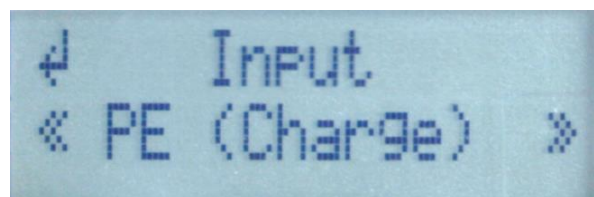

Figure 6: Input edit mode

A blinking cursor on the bottom row indicates that the current Edit mode involves numerical input. Use the LEFT and RIGHT buttons to change the cursor location. Use the UP and DOWN buttons to change the value of the current digit. To change the value for this type of function, simply use UP, DOWN, LEFT, and RIGHT to set the number to the desired option, and press ENT. The 2775C will return to View mode for that function, and the bottom row will display the value for the function.

See Figure 8: AC FSO edit mode. Note the cursor under the zero on the right.

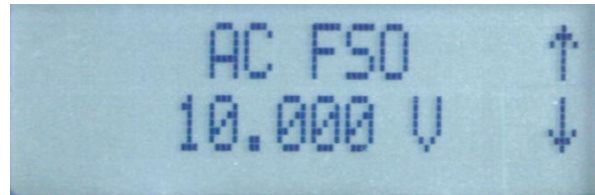

Figure 7: AC FSO view mode

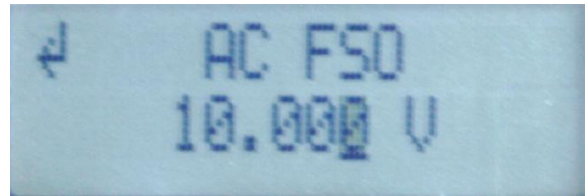

Figure 8: AC FSO edit mode

After power-up, the 2775C enters “RMS/DC Output” mode. The front panel shows a bar graph that indicates the DC output. See Figure 9: RMS/DC Output Screens. This can be used to get a visual impression of the DC output in real time, without the need for an outside DAQ. During menu navigation, if no action is taken for 20 seconds (while in view mode), the screen will revert back to “RMS/DC Output”.

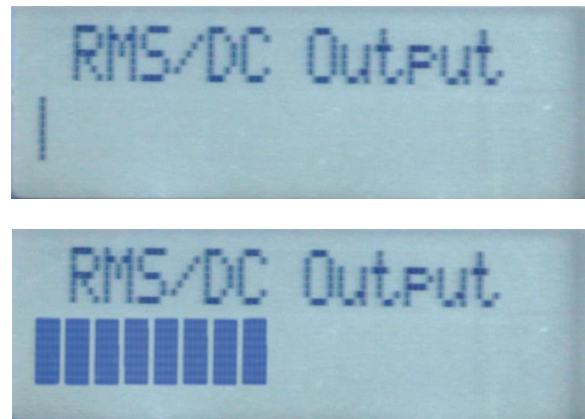

Figure 9: RMS/DC Output Screens

4.0 Standard Functions Menu

The 2775C has two front panel menus for two sets of functions, referred to as “Standard Functions” and “Advanced Functions”. The Standard Functions include more commonly used functions, while Advanced Functions include settings that are not changed regularly.

The UP or DOWN arrow buttons will exit the “RMS/DC Output” state. The 2775C is normally in the Standard Functions Menu. Press the UP or DOWN arrow buttons to scroll through the options.

The following functions are available in the Standard Functions Menu.

4.1. Mode

Description: Enables the operating mode and input port required.

Options:

- **"Sensor"**: Disables the OutCal and ExtCal functions.
- **"OutCal"**: Sets a 1000 Hz signal with an amplitude (V-pk) equal to the value entered in "Full Scale Output Range".
- **"ExtCal"**: External AC voltage signal applied to "ExtCal" input is routed to the front-end charge amplifier through a 1000 pF series capacitor. Sensor Input is disconnected from the amplifier when this calibration mode is selected and the IEPE current excitation is also disabled during this mode of operation.

Example of operation:

- Connect a signal generator to the "ExtCal" BNC connector on the rear panel.
- Change the value of the Mode function to "ExtCal".
- Multiply the "Full Scale Input Range" by the "Sensitivity" setting on the front panel. Example: 100 EU times 11.586 pC/EU equals 1158.6. Set the mV output of the signal generator connected in step one to this value: 1158.6 mV. The frequency can be anywhere within the pass band of the amplifier; however, 1000 Hz is recommended.
- Verify the AC, Servo, and DC outputs are at full scale.
- If using the 4830B, use the 2775C's sensor input since the 4830B can simulate either a charge-mode or IEPE accelerometer.
- Check the calibration connecting to the AC output of the 2775C to a precision, true RMS AC voltmeter. Use an oscilloscope to check for distortion and DC offset.

4.2. Sensor Type

Description: Selects the sensor type of the input signal.

Options:

- **"PE (Charge)"**: Piezo-Electric (PE) input is enabled.
- **"IEPE (Volts)"**: BNC Sensor Input is routed to the charge converter front-end through a series 1000 pF capacitor to accept sensors/devices with millivolt (AC) type output. IEPE (ISOTRON) current excitation is enabled during this mode of operation.

4.3. T-Insert

Description: Enables the T-Insert mode.

Options:

- **"Off"**: T-Insert mode is disabled.

- **"Ext Osc"**: Uses the external AC voltage signal applied to the "ExtCal/T-Insert" BNC connector. The signal is routed to the low side of the PE/charge sensor's input. Sensor input stays connected to the amplifier during this mode of operation.

4.4. FS Input Mode [EU]

Description: Selects the maximum signal amplitude in Engineering Units (EU) applied to the sensor. The user selects a Full Scale (FS) Range value from 0.01 EU to 100 000 EU limited by the gain <10,000 constraint. If the maximum signal amplitude is not known, enter a higher than expected value to reduce the risk of clipping the signal.

Options:

- **0.01, 0.03, 0.1, 0.3, 1, 3, 10, 30, 100, 300, 1K, 3K, 10K, 30K, 100K**

The Full-Scale Input Range is modified automatically if either Sensor Sensitivity or Full-Scale Output Range causes the unit to compute the amplifier's gain > 10,000.

4.5. Sensor Sensitivity [mV/EU, pC/EU]

Description: Allows the user to enter the sensitivity of the transducer in mV/EU for Voltage input, or pC/EU for Charge input. The Model 2775C automatically sets the gain level to achieve the required output scaling (FSO/FSI).

Options:

- **Range: 0.001 to 9999.000**

4.6. (Servo Output Scaling) [mV/EU]

Description: This function provides an AC output proportional to the vibration output level. A common use of this function is to provide a shaker controller/servo with an AC level proportional to amplitude. Select one of five fixed servo output-scaling settings.

Options:

- **0.1**
- **1.0**
- **10.0**
- **100.0**
- **1000.0**

4.7. Front End Filter

See Figure 10: Filter block diagram to visualize the 2775C filtering setup.

Description: Selects either the 0.5 Hz or 2.0 Hz one-pole Butterworth High-Pass filter (6 dB/octave).

Options:

- 0.5 Hz HPF
- 2.0 Hz HPF

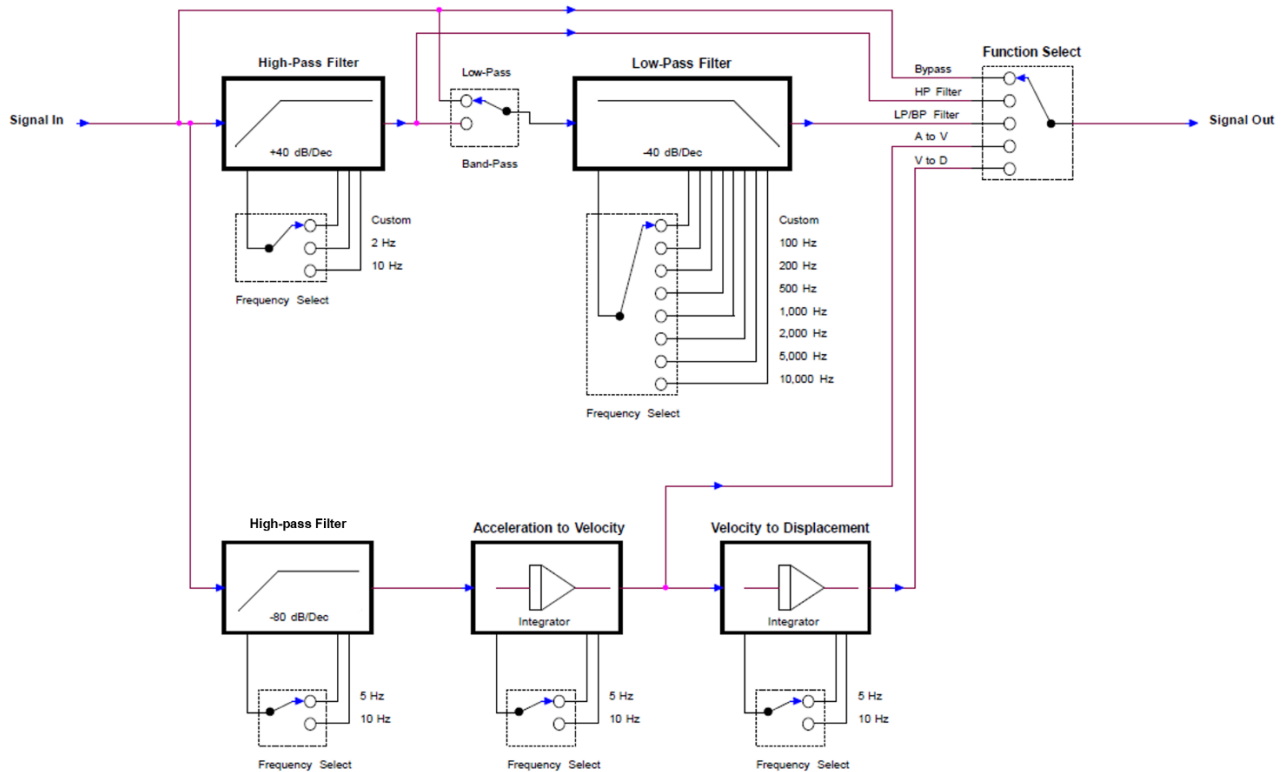

Figure 10: Filter block diagram

4.8. Output filter

Description: Selects a filter or velocity integrator or displacement integrator as a post-processing to the sensor signal.

Options:

- **“None”**: No back filter will be applied.
- **“HPF”**: A custom high pass filter is applied.
- **“LPF”**: A custom low pass filter is applied.
- **“Custom BPF”**: A custom band pass filter is applied. The frequency range is determined by the settings of the high pass filter and low pass filter frequencies selected.
- **“A/V Integ”**: The accelerometer’s signal is integrated to velocity.
- **“A/D Integ”**: The accelerometer’s signal is integrated to displacement.

4.9. Emulate 2775B

Description: When the 2775C is in 2775B Emulation Mode, the 2775C may be operated using the same RS-232 commands as used in the 2775B. This allows the 2775C to be backwards-compatible with existing test systems that already use the 2775B.

Options:

- **“No”**: The 2775C may be operated via RS-232 connection using its updated command list. The 2775C will report its identity via RS-232 as “2775C Rev A” in this mode.
- **“Yes”**: The 2775C may be operated via RS-232 using the 2775B command list. The 2775C will report its identity via RS-232 as “2775B Rev C” in this mode.

4.10.AC FSO (AC Full Scale Output) [V]

Description: Sets the full-scale output voltage at the AC output (and DC output when selected) from 0.001 to 10.0 volts peak. This voltage level is present at the AC output when the amplifier is in OutCal mode.

Options:

- **Range: 0.001 to 10.000.**

With the full-scale output voltage set to 10.0 and the full-scale input range set to 100, the AC output is scaled to 100mV/EU.

Input in Engineering Units (EU)	% of full scale	Output in volts peak
100	100	10
80	80	8
60	60	6
40	40	4
20	20	2
10	10	1

If the Full-Scale Output Range is incremented to the point where the amplifier’s gain is greater than 10,000, the Full-Scale Input of the 2775C will automatically be adjusted to meet the Amplifier Gain < 10,000 constraint.

4.11.Isolation

Description: Selects the isolation between the input and output common

Options:

- **“Isolated”**: Input common isolated from output common.
- **“Ground”**: Input common and output common connected together (no isolation).

4.12.Excitation (Current) [mA]

Description: Selects the excitation current level for the IEPE/RCC device connected to the Sensor Input

Options:

- **4.3 mA**
- **9.2 mA**
- **Off**

Never exceed the maximum current specified on the accelerometer’s datasheet. Use the minimum current (within the datasheet specifications) to ensure minimum heating of the transducer’s electronics and maximum life of the transducer. It may be necessary to use high current if driving long lines between the 2775C and the sensor.

5.0 Advanced Functions menu

To open the Advanced Functions menu, press the UP or DOWN arrows on the front panel to go to the Advanced Functions screen.

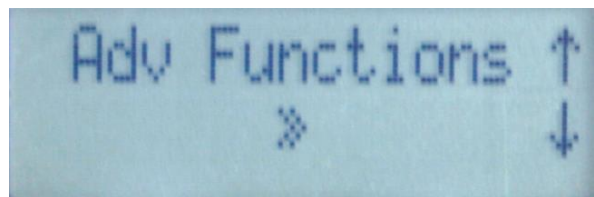

Figure 11: Advanced Functions screen

Press the ENT button to go to the Advanced Function screens.

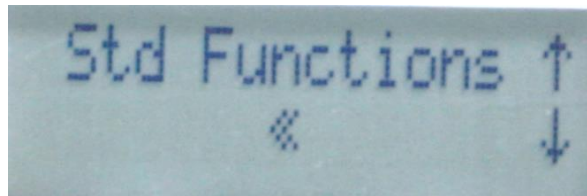

Figure 12: Standard Functions screen

If no action is taken for 20 seconds (while in view mode), the screen will revert back to “RMS/DC Output” with a visual indicator of the current RMS/DC output level.

5.1. LPF Switches

Description: This function has a view only mode, and is not editable from the Front Panel. This function displays the current setting of the custom Low Pass Filter determined by the internal 2775C hardware and switch positions.

5.2. HPF Switches

Description: This function has a view only mode, and is not editable from the Front Panel. This function displays the current setting of the custom High Pass Filter determined by the internal 2775C hardware.

5.3. Integ Switches

Description: This function has a view only mode, and is not editable from the Front Panel. This function displays the current setting of the custom Integrator determined by the internal 2775C hardware and switch settings.

If the switches are in an illegal configuration, the message “Bad Sw Config” will be displayed.

5.4. RS-232 Baud Rate

Description: Sets the baud rate of the RS-232 interface. Any of the arrow buttons may be used to select the baud rate.

5.5. Unit Address

Description: Sets the address of the 2775C unit.

Options:

- **Range: 1-20, inclusive**

5.6. IP Address

Description: Sets the IP address of the unit. Power must be cycled for changes to take effect.

Options:

- **Range: 0.0.0.1 to 255.255.255.254**

5.7. Netmask

Description: Sets the netmask of the unit. Power must be cycled for changes to take effect.

Options:

- **Range: 0.0.0.1 to 255.255.255.254**

If any of the four individual fields are set to a number greater than 255, the actual value stored for that field will be the result of $(x \text{ modulo } 255)$, where x is the value of the field.

5.8. Gateway

Description: Sets the gateway of the unit. Power must be cycled for changes to take effect.

Options:

- **Range: 0.0.0.1 to 255.255.255.254**

If any of the four individual fields are set to a number greater than 255, the actual value stored for that field will be the result of $(x \text{ modulo } 255)$, where x is the value of the field.

5.9. Cal Constants K1-K16

Description: During the factory calibration process, it is necessary to adjust various levels, such as gain, in the 2775C circuits to ensure the 2775C is in compliance with an external standard. The original calibration constants are stored in the 2775C memory and are also included on the calibration certificate. In Figure 13: Calibration Constant screen, it took a calibration constant of 0.973 to bring the AC output within the required specification.

The calibration constants can be set using the front panel buttons, or via the web interface. Note that the range available is recorded in the last column. If any of these constants are changed by the user, the calibration is considered void. In case any of these constants are inadvertently changed, refer to the calibration certificate and enter the correct number using the front panel.

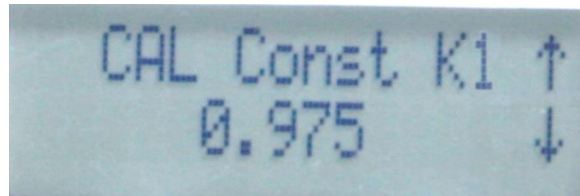

Figure 13: Calibration Constant screen

Figure 14: Calibration certificate shows a sample of a calibration certificate provided with each 2775C. The calibration constants are the results of the last calibration.



Date: 10/23/20 11:59 AM
 S/W Rev.- REV C
 Slot #4

PCB Piezotronics of NC, Inc. d/b/a Endevco
 10869 Highway 903, Halifax, NC 27839
 Fax: 716-685-3886 Telephone: 888-684-0013

Certificate of Calibration

Model: 2775B **Serial Number: Test 2**

This calibration was performed with Test and Measurement Equipment (T&ME), whose calibration is current and traceable to the National Institute of Standards and Technology (NIST) and is in compliance with ANSI / NCSL Z540-1-1994 (MIL-STD-45662A).

Test Console: 50220 Console Calibration Due date: May 14, 2020
 Humidity: 53% Temperature: 70°F
 Tested By: Randy Johnson Inspected by:

Cal No.	Calibration	Primary Out	Servo Out	Limits
1	K1:G2000, AC Out	0.969	N/A	0.80 to 1.20
2	K2:G200, GS200, AC Out	0.978	N/A	0.80 to 1.20
3	K3:G20, GS20 AC Out	0.971	N/A	0.80 to 1.20
4	K4:G2, GS2, AC Out	0.968	N/A	0.80 to 1.20
5	K5:G0.2, GS0.2, AC Out	0.967	N/A	0.80 to 1.20
6	K6: G2, PE, AC Out	0.966	N/A	0.80 to 1.20
7	K7:G2, DC Out	0.975		0.80 to 1.20
8	K8:G2, GS200, Servo Out	N/A	0.979	0.80 to 1.20
9	K9:G2, GS20, Servo Out	N/A	0.975	0.80 to 1.20
10	K10:G2, GS2, Servo Out	N/A	0.965	0.80 to 1.20
11	K11:G2, GS0.2, Servo Out	N/A	0.964	0.80 to 1.20
12	K12:G0.2, GS0.2, Servo Out	N/A	1.000	0.80 to 1.20
13	K13:G0.2, GS2, Servo Out	N/A	1.000	0.80 to 1.20
14	K14:G0.2, GS20, Servo Out	N/A	1.165	0.80 to 1.20
15	K15:G2, OutCal	0.886	N/A	0.80 to 1.20
16	K16:G2,GS2, PE, Servo Out	N/A	0.963	0.80 to 1.20

Test No.	Test Description	Primary Out	Servo Out	Limits	Unit
1a	IEPE Noise, 249 Ohm, G10000	0.033	N/A	0.0 to 0.1005	Vrms
1b	IEPE Noise, 249 Ohm, G10000	N/A	0.003	0.0 to 0.0105	Vrms
2	Vdclload 249 Ohm	1.075		0.950 to 1.245	Vdc
3a	PE Noise, G10000, AC Out	0.117	N/A	0.0 to 0.1005	Vrms
3b	PE Noise, GS1000, Servo Out	N/A	0.013	0.0 to .0105	Vrms
4	IEPE Noise, 249 Ohm, G10	0.002	N/A	0.00 to 0.010	Vrms
5	Output DC Offset, G5, GS5	0.000	-0.001	-0.020 to 0.020	Vrms
6	Output DC Offset, DC Out	-0.003		-0.030 to 0.030	
7	Freq 100 Hz, G5 & GS5 Ref	1.000	1.001	0.995 to 1.005	Vrms
8	Freq 2Hz, G5, GS5, -5%	0.954	0.954	0.95 to 1.05	Vrms
9	Freq 50Khz, G5, GS5, -5%	1.035	1.035	0.94 to 1.06	Vrms
10	Freq 120Khz, G5 & GS5, -3db	1.113	1.095	0.83 to 1.17	Vrms
11	Freq 100Hz, G0.5, GS0.5	1.001	1.001	0.995 to 1.005	Vrms
12	Freq 100Hz, G5, GS0.5	N/A	1.001	0.995 to 1.005	Vrms
13	Freq 100Hz, G50, GS50	0.998	1.000	0.995 to 1.005	Vrms
14	Freq 100Hz, G500, GS500	1.001	1.000	0.995 to 1.005	Vrms
15	Freq 100Hz, G5000	0.999	N/A	0.995 to 1.005	Vrms
16	Freq 100Hz, G5 (DC)	1.001		0.99 to 1.01	Vdc
17	Freq 100Hz, G5, GS5	1.000	1.000	0.995 to 1.005	Vrms
18	Outcal Full Scale 10V@ 1Khz	7.066	N/A	6.928 to 7.211	Vrms
19	Outcal Frequency	993.060	N/A	900.0 to 1100.0	Hz
20	Extcal, Freq 100Hz, G5, GS5	1.000	1.002	0.98 to 1.02	Vrms
21	T-Insert, Freq 100Hz, G5, GS5	0.944	0.944	0.90 to 1.10	Vrms
22	CMRR, G10000, 7V @ 1000Hz	1.732	0.181	.01 to 3.5	Vrms
23	IEPE Fault, 1V<Input> 19Vdc	PASS	N/A	pass/fail	
24	Output OVLD Fault	PASS	N/A	pass/fail	
25	PASS	PASS	N/A	pass/fail	

Figure 14: Calibration certificate

Options:

- Range: 0.800 to 1.200

5.10.Factory Restore

Description: Allows the user to return all the user settings to the factory settings.

Options:

- Yes, No

6.0 Web Interface

The 2775C may be controlled via its web interface. The factory web server IP address is 192.168.1.100. The factory web page address is <http://192.168.1.100/>. The IP address may be viewed and changed using the front panel.

For best performance, use the Google Chromium browser.

6.1. Mode Tab

The Mode tab is shown in Figure 15: Mode tab. The available modes are Sensor, Out Cal, External Cal and T-Insert.

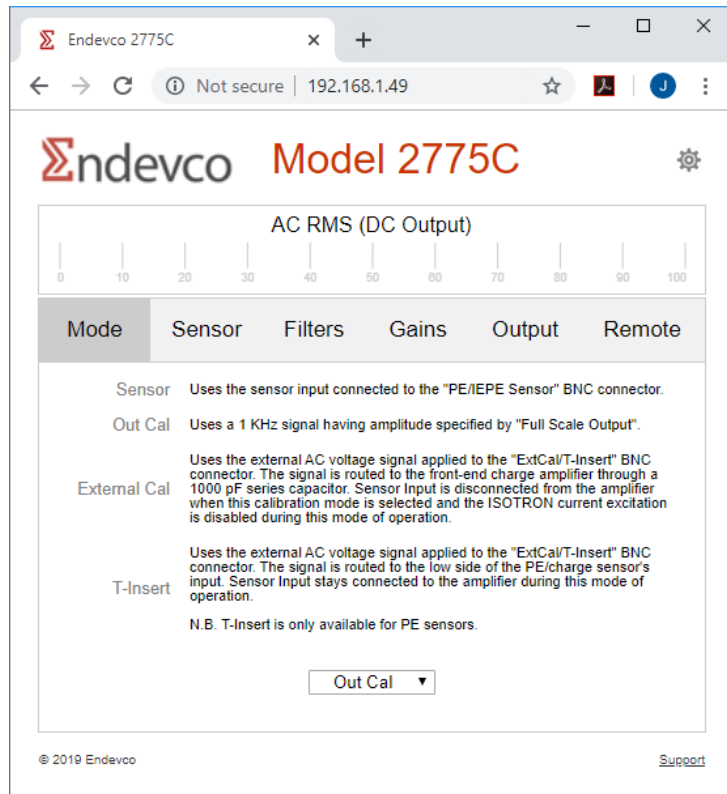

Figure 15: Mode tab

6.2. Sensor Tab

The Sensor tab is used to set the attached sensor's characteristics. See Figure 16: Sensor tab. The sensor's type, excitation current, sensitivity, full scale input and isolation are specified using the drop-down menus.

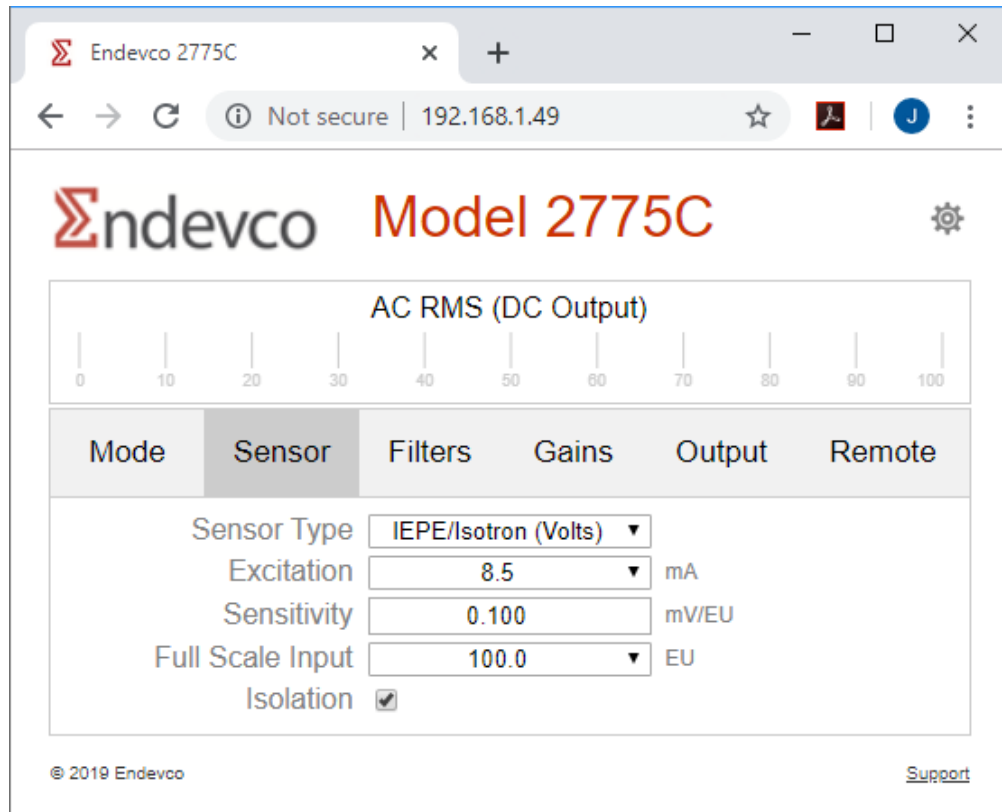

Figure 16: Sensor tab

6.3. Filters Tab

The Filters tab is used to control the signal path filters. See Figure 17: Filters tab.

The Switches section shows the configuration of the internal switches. See Internal Switches section.

The Settings section controls the front-end high-pass filter (HPF) and the filter/integrator section.

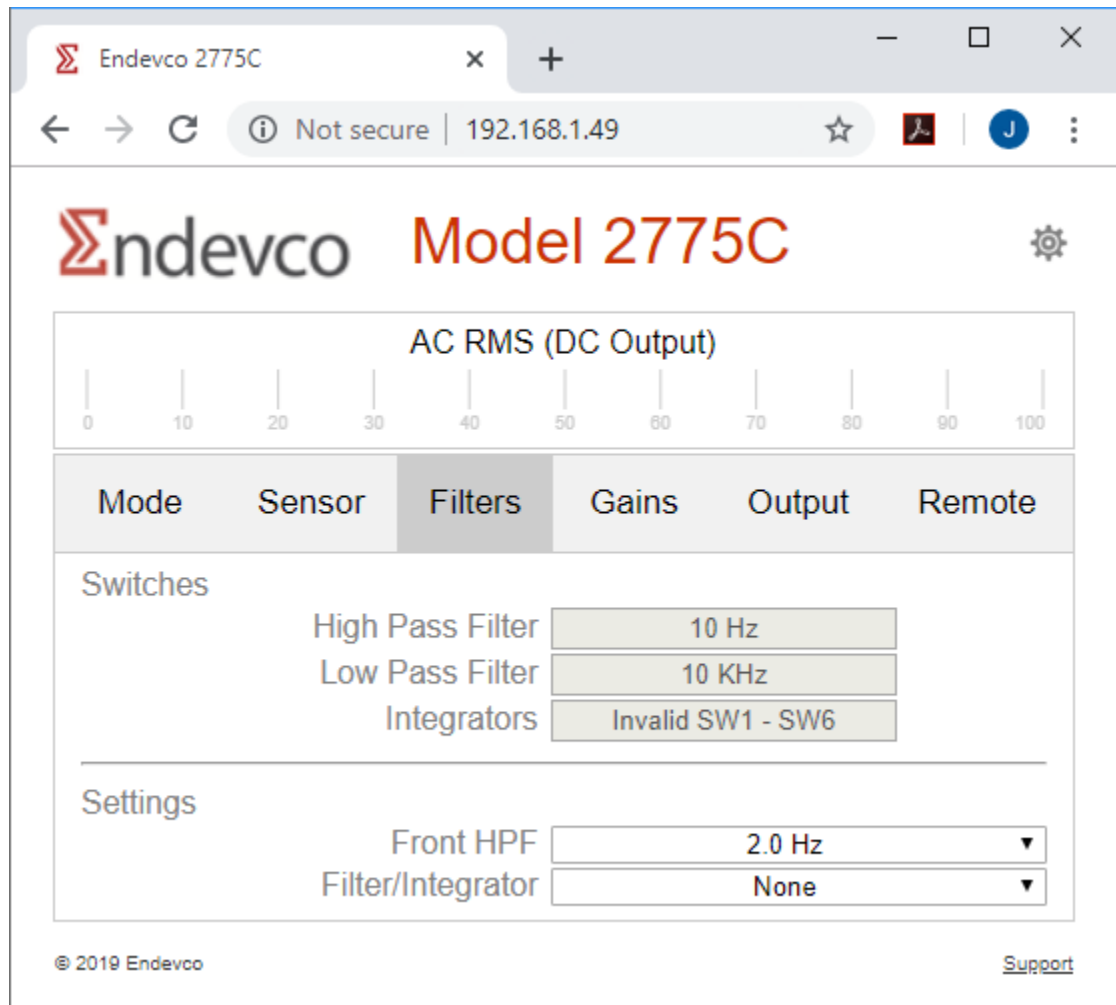

Figure 17: Filters tab

6.4. Gains Tab

The Gains tab shows the internal gain stages and their current values. See Figure 18: Gains tab. Gains are computed automatically whenever sensitivity, full-scale input (FSI) or full-scale-output (FSO) are changed. This tab allows the user to override the automatic gain processing.

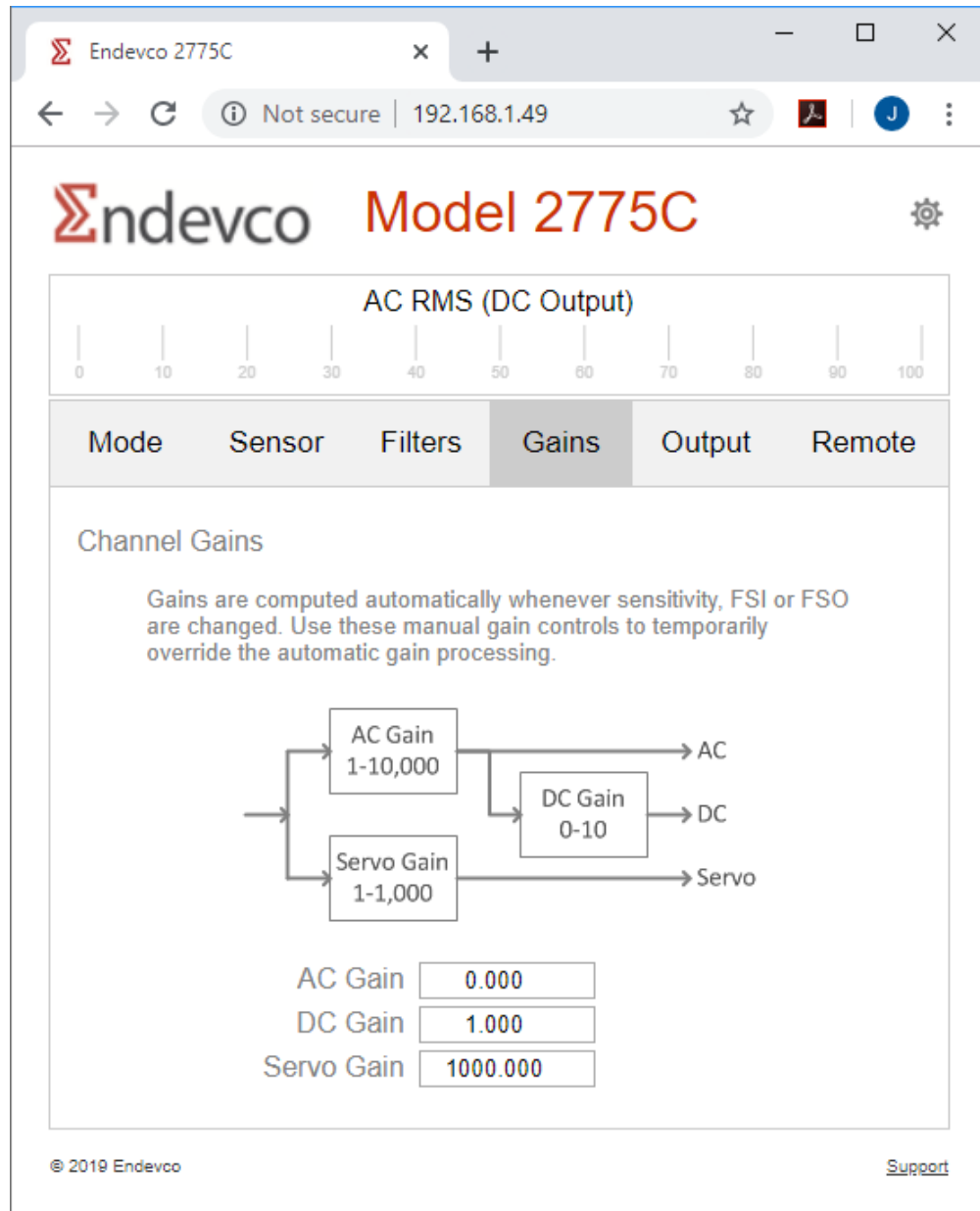

Figure 18: Gains tab

6.5. Output Tab

The Output tab controls the full-scale output of the unit. See Figure 19: Output tab.

Note that changing these settings will change the system gain.

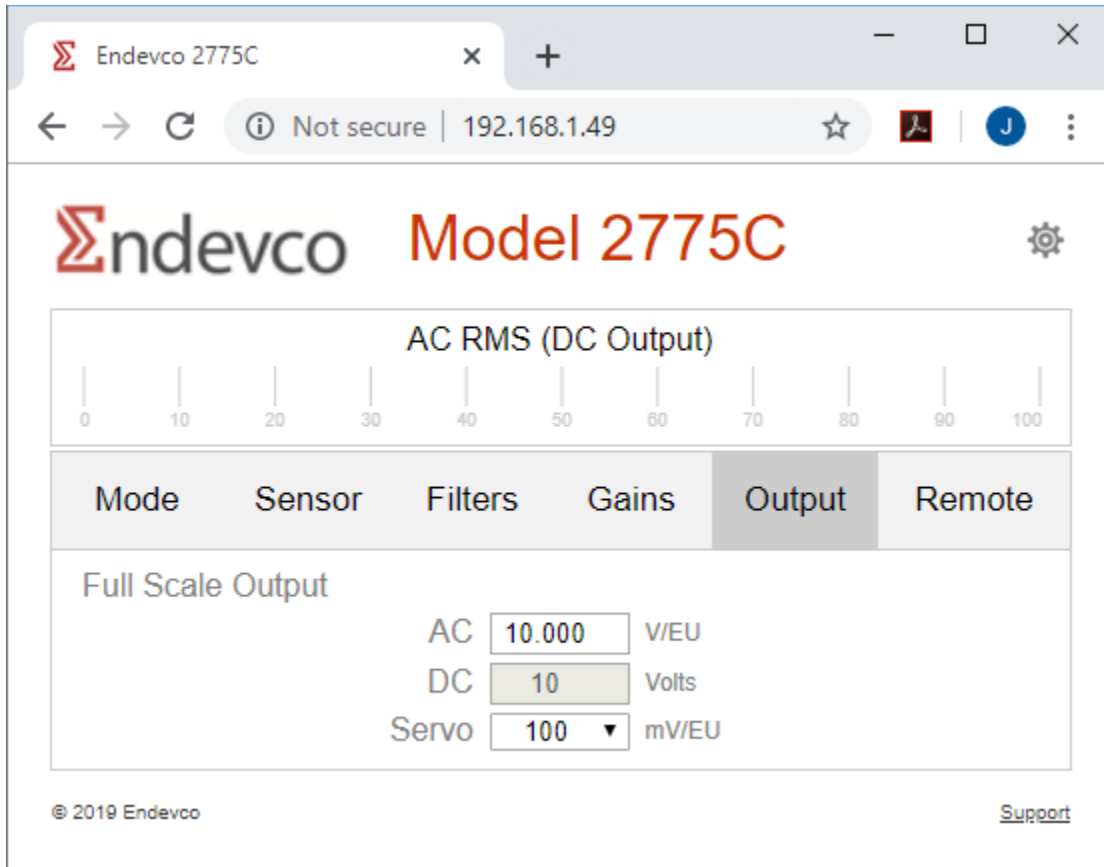

Figure 19: Output tab

6.6. Remote Tab

The Remote tab displays the remote control configuration items. See Figure 20: Remote tab. The following remote control data items may be changed: the unit address, the Ethernet IP address, netmask and gateway, and the RS232 baud rate.

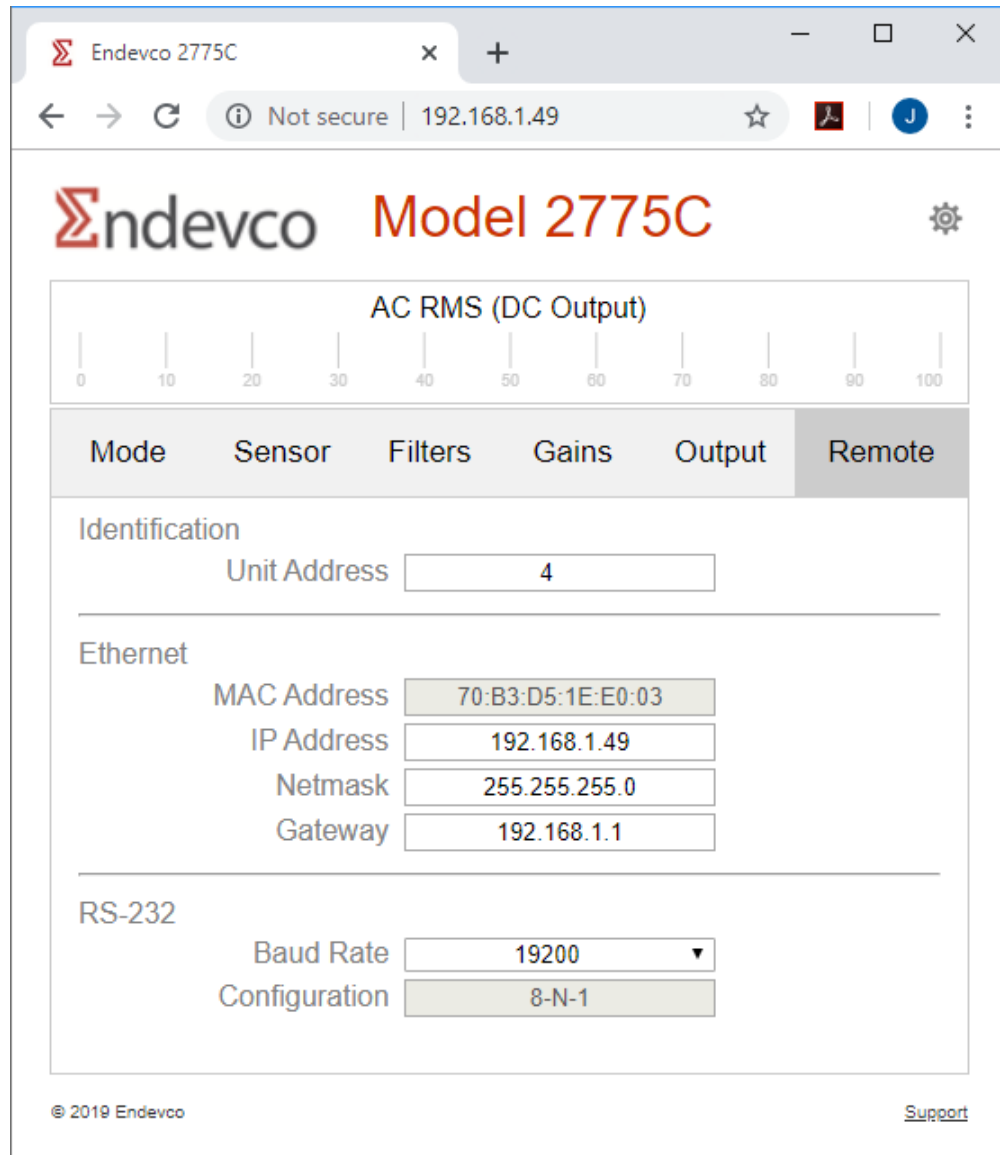

Figure 20: Remote tab

6.7. Settings page

Click on the gear icon to display the system settings page. See Figure 21: Settings page. The settings page shows the calibration constants and allows the user to return the unit to its factory settings.

Changing a factory calibration constant voids the warranty.

Restoring the factory settings will change the IP address back to 192.168.1.100, which may cause the web page to become unresponsive.

Endeveco Model 2775C

AC RMS (DC Output)

0 10 20 30 40 50 60 70 80 90 100

Calibration Constants

	Output Mode	Condition	Value
K1	AC IEPE	1000 ≤ Gain ≤ 10,000	0.973
K2	AC IEPE	100 ≤ Gain < 1000	0.983
K3	AC IEPE	10 ≤ Gain < 100	0.981
K4	AC IEPE	1 ≤ Gain < 10	0.977
K5	AC IEPE	0 ≤ Gain < 1	0.967
K6	AC PE	1 ≤ Gain < 10	0.966
K7	DC IEPE	1 ≤ Gain < 10	1.000
K8	Servo IEPE	100 ≤ Gain < 1000	1.000
K9	Servo IEPE	10 ≤ Gain < 100	1.184
K10	Servo IEPE	1 ≤ Gain < 10	0.901
K11	Servo IEPE	0 ≤ Gain < 1	0.974
K12	Servo IEPE	0 ≤ Gain < 1	1.000
K13	Servo IEPE	1 ≤ Gain < 10	1.000
K14	Servo IEPE	10 ≤ Gain < 100	1.000
K15	AC OUTCAL	FSO = 2	1.000
K16	Servo PE	1 ≤ Gain < 10	1.000

Factory Settings

Click the following button to return this unit to its factory settings.
The IP address will revert to 192.168.1.100 with netmask
255.255.255.0. The above calibration constants will be unaffected.

© 2019 Endeveco Support

Figure 21: Settings page

7.0 Internal Switches

Internal switches are provided to allow the user to configure the signal conditioner to the test requirements. See Figure 3: Filter and integrator switches for the location of these switches. Switching to the “ON” position will activate the appropriate circuit to perform the desired function, e.g. integrate to velocity, etc. The “ON” position and switch dash number is marked on each switch (see Figure 22: Filter/Integrator switch). See Figure 3: Filter and integrator switches for the location of the switches.



Figure 22: Filter/Integrator switch

The table below is provided to guide the user as to what switch/switches need to be turned on in order to activate the required function. Each switch is identified as SW1 – SW6 on the top row and SW7 – SW12 on the lower row.

LP Corner Frequency (Hz)	Switch Number							
	9-1	9-2	10-1	10-2	11-1	11-2	12-1	12-2
Custom	On	Off	Off	Off	Off	Off	Off	Off
100	Off	On	Off	Off	Off	Off	Off	Off
200	Off	Off	On	Off	Off	Off	Off	Off
500	Off	Off	Off	On	Off	Off	Off	Off
1k	Off	Off	Off	Off	On	Off	Off	Off
2k	Off	Off	Off	Off	Off	On	Off	Off
5k	Off	Off	Off	Off	Off	Off	On	Off
10k	Off	Off	Off	Off	Off	Off	Off	On

HP Corner Frequency (Hz)	Switch Number			
	7-1	7-2	8-1	8-2
Custom	On	Off	Off	Off
10	Off	On	Off	Off
2	Off	Off	On	Off

Velocity & Displacement Frequency (Hz)	Switch Number											
	1-1	1-2	2-1	2-2	3-1	3-2	4-1	4-2	5-1	5-2	6-1	6-2
5	On	Off	On	Off	On	Off	On	Off	On	Off	On	Off
10	Off	On	Off	On	Off	On	Off	On	Off	On	Off	On

8.0 T-Junction Calibration

The Voltage insertion, or T-Junction calibration and/or a functionality test is an exclusive feature on the 2775C. While more conventional calibration methods are usually utilized, the T-junction method is an excellent way to test remote, or difficult to reach transducers.

For a better understanding of the process, Figure 23 illustrates how a T-Junction calibration is configured. Notice that the signal is injected via the shield, but with the 2775C there is no need to cut the cable.

Figure 23: T-Junction wiring diagram illustrates how the components come together. The 2775C reduces the external components required and no cutting of the cable is necessary. The mounting stud is an insulated type since the accelerometer and 2775C grounds must be isolated. The calibration voltage is provided by an external signal generator that is connected to the 2775C's ExtCal input.

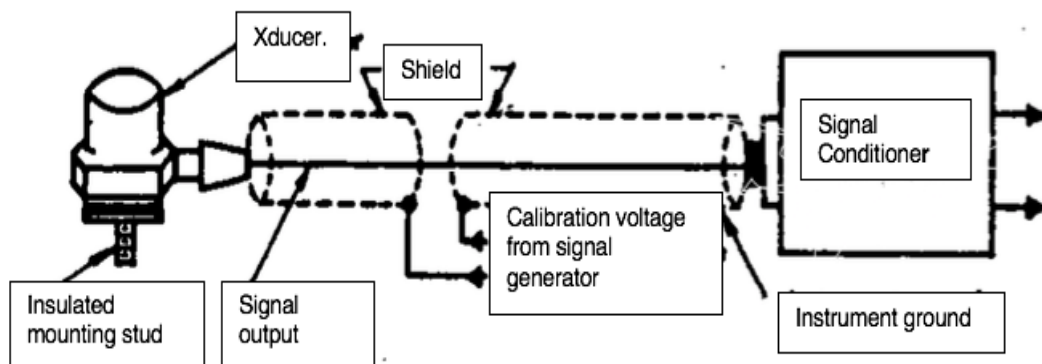

Figure 23: T-Junction wiring diagram

8.1. Test Procedure

- Power-up the 2775C until the RMS/DC mode appears on the unit's screen
- Press the up or down arrow buttons until the T-Insert screen appears, press ENT
- Press the up or down arrow buttons until the Sensor Type screen appears, press ENT
- Select PE (Charge) and press ENT
- Select FSI and press ENT
- Select 100, for the below example while there are other FS settings available.
- Continue to set up the other parameters
- Connect a sine wave signal source to the "ExtCal" input
- Connect the charge-mode piezoelectric sensor to the "Sensor" input
- Connect a BNC cable from the AC output to an oscilloscope input
- Input the sensor's sensitivity using web page or the front panel controls. In this example, use 11.586. The actual sensitivity is printed on the calibration certificate and on the box's label.

To simulate a full-scale output the following formula is used:

$$E = \frac{FSI}{Ct}$$

Where:

E = Full scale voltage applied to ExtCal input

FSI = Full scale input

Ct = total capacitance of the accelerometer plus cable

Note: The capacitance of the accelerometer is available on the accelerometer's calibration certificate or data sheet.

Example:

With the FSI set at 100 and the total capacitance (accelerometer + cable) of 11.586 pF/g requires 1158.6 pC to simulate 100g's.

$$E = 100 \times \frac{11.586}{3105}$$

$$E = 0.373 \text{ Volts}$$

Parameters for Calibration:

Some additional calculations should be made if the T-Junction is being used to conduct an accurate calibration check.

Since the 2775C is a charge amplifier, the calibration resistance, usually the output resistance of the external signal generator. R_{cal} must meet the following:

$$R_{cal} \ll \frac{1}{\omega (Cp + C1)}$$

Once the resistance is determined to be acceptable, the calibration voltage level can be determined:

$$E_{cal} = \frac{qp}{Cp + C1}$$

Where:

Cp = Transducer capacitance in pF

C1 = External capacitance in pF between the accelerometer and the signal input connector. This can be the cable capacitance.

qp = Transducer charge sensitivity pC peak for peak g.

Ecal = Calibration voltage sensitivity in peak volts/peak g.

Rcal = Calibration resistance, the output resistance of the signal generator.

Prior to using the T-Junction calibration feature, it is recommended that the user review Endevco Technical Paper TP216, available on the Endevco web site.

9.0 Safety

9.1. Safety Considerations

This product is intended for use by qualified personnel who recognize shock hazards and are familiar with the precautions required to avoid injury. While our equipment is designed with user safety in mind, the protection provided by the equipment may be impaired if equipment is used in a manner not specified by this manual.

9.2. Definition of Terms and Symbols

The following symbols may be found on the equipment described in this manual:



CAUTION

Caution is necessary when operating the device close to where the symbol is placed. User should refer to the operating instructions located in the manual.



DIRECT CURRENT

To indicate that the equipment is suitable for direct current only; and to identify relevant terminals.



ELECTRONIC WASTE

To indicate that separate collection for waste electric and electronic equipment (WEEE) is required.

9.3. Ground the instrument

To minimize shock hazard and minimize electrical noise, the instrument chassis and cabinet must be connected to an earth - ground. The instrument's power supply is equipped with a three-conductor AC power plug. The power plug must either be plugged into an approved three-contact electrical outlet or used with a three-contact to two-contact adapter with the grounding wire (green) firmly connected to an electrical ground (safety ground) at the power outlet. The power jack and mating plug of the power cable meet International Electrotechnical Commission (IEC) safety standards.

9.4. ESD protection



This unit contains ESD sensitive parts. When the unit is opened, ensure service personnel observe all ESD precautions.

9.5. Do not substitute parts or modify the instrument

Because of the danger of introducing additional hazards, do not install substitute parts or perform any unauthorized modification to the instrument.

10.0 Repairs and Calibration

For repair or replacement of a defective instrument, or calibration, contact Endevco and obtain an RMA number prior to returning the instrument.

Appendix A: Using high temperature charge-mode accelerometers

The 2775C has a minimum source resistance of 10 M Ω , which is capable of supporting most accelerometers. When using accelerometers at high temperatures, the resistance of the sensing material drops below the minimum source (input) resistance of the 2775C.

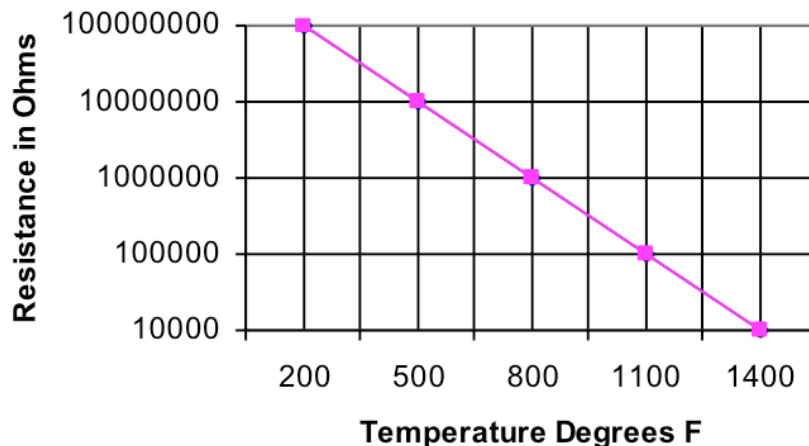

Figure 24 Temperature vs Resistance

Figure 24 Temperature vs Resistance is an example of a typical temperature vs. resistance plot. Note that the minimum source resistance is maintained up to approximately 500° F (260°C). Consult the accelerometer’s datasheet for the actual resistance vs. temperature specifications.

For source resistance <10 M Ω , it is recommended that a model 2771C Remote Charge Converter (RCC) be used between the signal conditioner and the sensor. Since the 2771C RCC has a minimum input resistance of 100 k Ω , the accelerometer will operate well up to 1100°F.

Appendix B: RS-232 Remote Control Application Program Interface (API)

This section describes the RS-232 remote control commands and their responses.

COMMANDS

Commands sent to the 2775C are ASCII strings having the following format:

```
<model + unit_address> <channel> <command>; [<arguments> ]<checksum><terminator>
```

- The model is 512 for the 2775B, and 768 for the 2775C.
- The unit address is set from the front panel of the 2775C or from the web pages. The range is 1-255. The broadcast address is 0.
- Channel is ignored as the 2775C has one channel.
- The commands are described in Table 1 – Commands.

Command	Description
0	Set state
1	Set Cal Constants
2	Get State
3	Get Cal Constants
8	Reset
9	Get ID
10	Get LPF Frequency
11	Get Errors

Table 1 – Commands

- The checksum is the unsigned 8-bit sum of the characters that precede it.
- The terminator can be a carriage return (13) or a line feed (10).

RESPONSES

There are 3 types of responses.

- “Set” commands generate an ACK response.
- “Get” commands generate a data response.
- Bad commands generate a NAK response.

The response line terminator is always a line feed (10).

ACK

An ACK response has the following format:

```
<unit_address> 0 12;<terminator>
```

NAK

A NAK response has the following format:

```
<unit_address> 0 13;<reason> <terminator>
```

Malformed commands are ignored. Well-formed commands will generate a NAK response if any of the reasons described in Table 2 - NAK Reasons are true.

Reason	Description
0	Command unsupported
2	Missing a data field
3	Bad checksum
5	Data field out of range

Table 2 - NAK Reasons

Data Response

“Get” command responses have the following form:

```
<unit_address> 0 <command>;<data> <terminator>
```

COMMAND DETAILS

In the examples provided below, the unit number is 1 and “Emulate 2775B” is off.

SET SETTINGS (0)

Command

```
<model + unit_address> 1 0;<FSI> <Sensitivity> <AC FSO> <Servo FSO> <Input> <Plug In Filter> <Isolation>  
<Front HPF> <checksum><terminator>
```

Response

If no errors occur, an ACK is returned:

```
<unit_address> 0 12;<terminator>
```

Example

Command

```
769 1 0;0 1000 1000 3000 2000 1000 0 1000 107\n
```

Response

```
1 0 12;\n
```

SET CAL CONSTANTS (1)

Command

```
<model + unit_address> 1 1; <K1> <K2> <K3> <K4> <K5> <K6> <K7> <K8> <K9> <K10> <K11> <K12> <K13>  
<K14> <K15> <K16> <checksum><terminator>
```

where the K values are the internal cal constants multiplied by 1000. For example, “1012” would correspond to an internal value of 1.012.

Response

If no errors occur, an ACK is returned:

```
<unit_address> 0 12;<terminator>
```

Example

Command

```
769 1 1;1000 1000 1000 1000 1000 1000 1000 1000 1000 1000 1000 1000 1000 1000 1000 1000 1000 147\n
```

Response

```
1 0 12; \n
```

GET SETTINGS (2)

Command

```
<model + unit_address> 1 2;<checksum><terminator>
```

Response

```
<unit_address> 0 2;<FSI> <Sensitivity> <AC FSO> <Servo FSO> <Input> <Plug In Filter> <Isolation> <Front  
HPF> <terminator>
```

where each setting is the internal value multiplied by 1000.

Example

Command

```
769 1 2;132\n
```

Response

```
1 0 2;0 1000 1000 3000 2000 1000 0 1000 \n
```

GET CAL CONSTANTS (3)

Command

```
<model + unit_address> 1 3; <checksum><terminator>
```

Response

```
<model + unit_address> 1 3; <K1> <K2> <K3> <K4> <K5> <K6> <K7> <K8> <K9> <K10> <K11> <K12> <K13>  
<K14> <K15> <K16> <checksum><terminator>
```

where the K values are the internal cal constants multiplied by 1000. For example, “1012” would correspond to an internal value of 1.012.

Example

Command

```
769 1 3;133\n
```

Response

```
1 0 3;1000 1000 1000 1000 1000 1000 1000 1000 1000 1000 1000 1000 1000 1000 1000 1000 1000 \n
```

GET UNIT ID (9)

Command

```
<model + unit_address> 1 9; <checksum><terminator>
```

Response

```
<unit_address> 0 9; <model number> <model revision> <terminator>
```

Example

Command

```
769 1 9;139\n
```

Response

```
1 0 9;2775C REV A \n
```

GET LPF (10)

This command is used for 2775B emulation and is deprecated for 2775C.

Command

```
<model + unit_address> 1 10; <checksum><terminator>
```

Response

```
<unit_address> 0 10; <terminator>
```

Example

Command

```
769 1 10;179\n
```

Response

```
1 0 10; \n
```

GET ERRORS (11)

Command

```
<model + unit_address> 1 11; <checksum><terminator>
```

Response

```
<unit_address> 0 11;<error code> <terminator>
```

The error code is the decimal representation of the bitmap described in Table 3 - Error bitmap.

Bit Number	Decimal Value	Description
0	1	Isolation error
1	2	IEPE/Open/Short
2	4	Overload
3	8	Bad FSI
4	16	Servo gain error

Table 3 - Error bitmap

For example, an isolation error (1) and an overload condition (4) would generate an error code of 5. 0 indicates no error.

Example

Command

```
769 1 11;180\n
```

Response

```
1 0 11;0 \n
```

GET MAC ADDRESS (20)

Command

```
<model + unit_address> 1 20;<checksum>
```

Response

If no errors occur, an ACK is returned:

```
<unit_address> 0 20;<MAC address> <terminator>
```

Example

Command

```
769 1 20;180\n
```

Response

```
1 0 20;70:B3:D5:1E:E0:01 \n
```

GET SERIAL NUMBER (21)

Command

```
<model + unit_address> 1 21;<terminator>
```

Response

If no errors occur, an ACK is returned:

```
<unit_address> 0 21;<serial number> <terminator>
```

Example

Command

```
769 1 21;181\n
```

Response

```
1 0 21;EN0000126 \n
```