

Endevco®

# 2950 Triaxial mounting blocks for PE and Isotron accelerometers

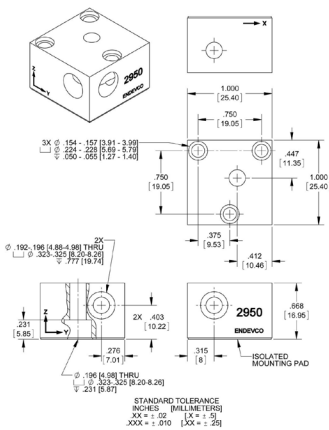

2950

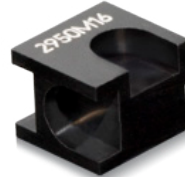
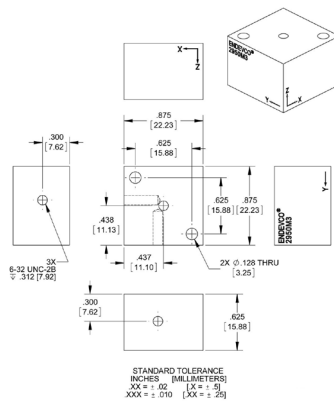

2950M3

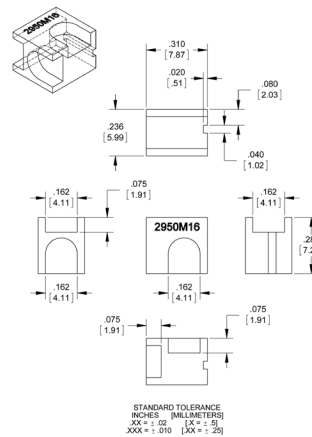

2950M16

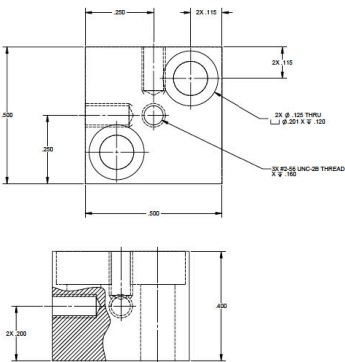

2950M18

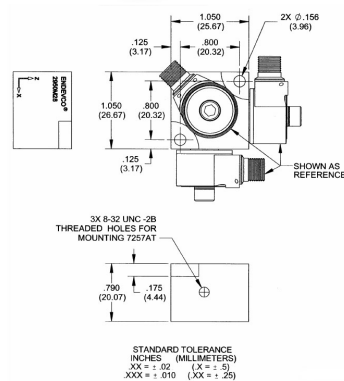

2950M28

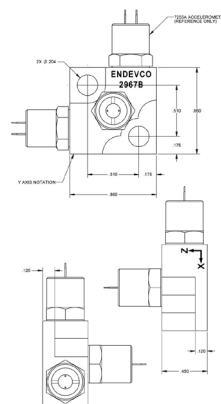

2967B

## Key features

- Compatible with Endevco brand accelerometers
- Adhesive and screw mounting
- Precision machined for maximum transmissibility
- Mounting hardware provided

## Meggitt Sensing Systems

Our measurement product competencies:

Piezoelectric accelerometers | Piezoresistive accelerometers | Isotron accelerometers | Variable capacitance accelerometers | Pressure transducers | Acoustic sensors | Electronic instruments | Calibration systems | Shakers | Modal hammers | Cable assemblies

**MEGGITT**  
smart engineering for  
extreme environments

Endevco®

# 2950 Triaxial mounting blocks

for PE and Isotron accelerometers



	2950	2950M3	2950M16	2950M18
<b>Description</b>	Triaxial mounting block, 10-32 threaded holes, 4-40 x 3 screw mount provided	Triaxial mounting block 6-32 threaded holes 4-40 x 7/8 screw mount provided	Triaxial mounting block Adhesive mount	Triaxial mounting block 2-56 threaded holes 4-40 x 1/2 screw mount provided
<b>Compatibility</b>	Accelerometers with 10-32 stud	2221D, 2221F, 7221A, 7251A	25A, 25B	2220E, 7250A, 7250AM1
<b>Mounting torque</b>	18 lbf-in	10 lbf-in	N/A	5 lbf-in
<b>Material</b>	Anodized aluminum	Anodized aluminum	Anodized aluminum	Anodized aluminum
<b>Flatness TIR</b>	0.0005	0.0005	0.001	
<b>Weight grams</b>	20.5	20.5	0.5	3.7
<b>Isolated</b>	Yes	Yes	Yes	Yes
<b>Max temp °C</b>	177	177	125	177



	2950M28	2967B
<b>Description</b>	Triaxial mounting block 8-32 threaded holes 6-32 x 7/8 screw mount provided	Triaxial mounting block 1/4-28 threaded holes 10-32 x 3/8 screw mount provided
<b>Compatibility</b>	7257AT	7555A, 2255B
<b>Mounting torque</b>	10 lbf-in	30 lbf-in
<b>Material</b>	Anodized aluminum	Titanium
<b>Flatness TIR</b>	0.0005	0.0005
<b>Weight grams</b>		
<b>Isolated</b>	Yes	No
<b>Max temp °C</b>	177	125

## Notes

1. Mounting screws supplied, where applicable.
2. Mounting tools supplied for 2950M3.
3. Removal tool supplied for adhesive mount 2950M16.
4. Maintain high levels of precision and accuracy using Meggitt's factory calibration services. Call Meggitt's inside sales force at 800-982-6732 for recommended intervals, pricing and turn-around time for these service as well as quotations for other products.

## Contact

### Meggitt Sensing Systems

14600 Myford Road  
Irvine  
CA 92606, USA  
Tel: +1 (949) 493 8181  
Fax: +1 (949) 661 7231

[www.endevco.com](http://www.endevco.com)  
[www.meggitt.com](http://www.meggitt.com)



Continued product improvement necessitates that Meggitt reserve the right to modify these specifications without notice. Meggitt maintains a program of constant surveillance over all products to ensure a high level of reliability. This program includes attention to reliability factors during product design, the support of stringent Quality Control requirements, and compulsory corrective action procedures. These measures, together with conservative specifications have made the name Endevco synonymous with reliability. 020416

**MEGGITT**  
smart engineering for  
extreme environments