

Piezoelectric accelerometer

Model 7703A -200, -1000

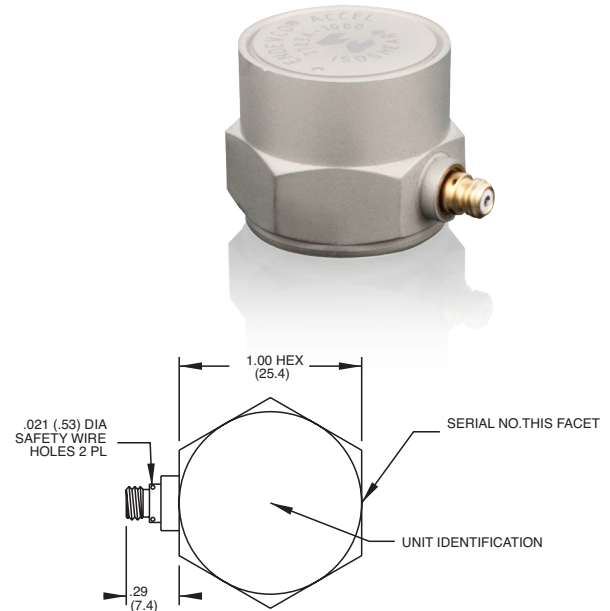
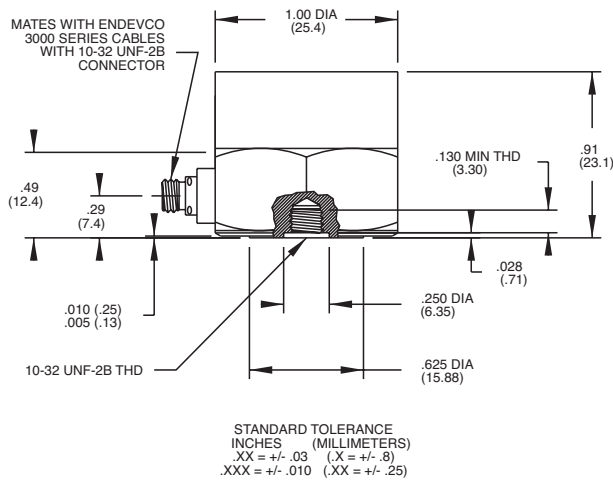

Key features

- Low base strain sensitivity
- Ground isolated
- Hermetically sealed
- Temperature compensated operation up to +550°F (+288°C)
- High output/modal applications
- Radiation environment up to 10⁸ rads

Description

The Endevco® model 7703A-XXXX Isoshear piezoelectric accelerometer is designed for modal measurement on large structures and objects. The Isoshear design is extremely stable and virtually insensitive to such environmental inputs as base bending and thermal transients. This line of accelerometers has been tested in a radiation environment up to 108 rads. They are also capable of measurement up to +550°F (+288°C). These units are hermetically sealed against external contamination. The accelerometer is a self-generating device that requires no external power source for operation.

The model 7703A-XXXX features Endevco's Piezite® type P-8 crystal element, operating in shear mode. This unit exhibits low base strain sensitivity, high resonance frequency, and excellent output stability over time. Signal ground is isolated from the outer case of the unit. The accelerometer features a 10-32 side-connector. A low-noise coaxial cable is supplied for error-free operation. The model number suffix indicates acceleration sensitivity in pC/g; i.e., 7703A-1000 features output sensitivity of 1000 pC/g.

Piezoelectric accelerometer | Model 7703A -200, -1000

The following performance specifications conform to ISA-RP-37.2 (1964) and are typical values, referenced at +75°F (+24°C) and 100 Hz, unless otherwise noted. Calibration data, traceable to National Institute of Standards and Technology (NIST), is supplied.

Specifications			
Dynamic characteristics	Units	-200	-1000
Charge sensitivity			
Typical	pC/g	200	1000
Minimum	pC/g	180	900
Frequency response		See typical amplitude response	
Resonance frequency			
Typical	kHz	17	7.5
Minimum	kHz	13	6
Amplitude response [1]			
±5%	Hz	1 to 4000	1 to 2000
±1 dB	Hz	1 to 6000	1 to 3000
Temperature		See typical curve	
-67°F (-55°C) max/min	%	13.6	13.6
+350°F (+177°C) max/min	%	-2.142857143	-2.142857143
+550°F (+288°C) max/min	%	-10.08333333	-10.08333333
Transverse sensitivity	%	≤ 3	≤ 3
Amplitude linearity	%	1/125 g	1/25 g
Up to vibration limit			
Electrical characteristics			
Output polarity	Acceleration directed into the base of unit produces positive output at center socket of receptacle		
Resistance [2]	GΩ	≥ 10	≥ 10
Resistance at +550°F (+288°C)	MΩ	≥ 25	≥ 25
Isolation	GΩ	≥ 1	≥ 1
at +550°F (+288°C)	MΩ	≥ 10	≥ 10
Capacitance	pF	5600	5600
Grounding		Signal return isolated from case	
Environmental characteristics			
Temperature range [3]		-67°F to +550°F (-55°C to +288°C)	
Humidity		Hermetically sealed	
Sinusoidal vibration limit	g pk	850	500
Shock limit [4]	g pk	2000	1000
Base strain sensitivity	equiv. g pk / μ strain	0.0004	0.00008
Electromagnetic sensitivity	equiv. g rms / gauss	0.0002	0.0001
Thermal transient sensitivity	equiv. g pk / °F (°C)	0.002 (0.004)	0.001 (0.002)
Radiation			
Integrated gamma flux	rad	up to 10 ⁸	up to 10 ⁸
Integrated neutron flux	N/cm ²	up to 10 ¹⁰	up to 10 ¹⁰
Physical characteristics			
Dimensions		See outline drawing	
Weight	gm (oz)	62 (2.2)	120 (4.2)
Case material		Stainless steel	
Connector		Coaxial receptacle with 10-32 UNF threads designed to mate with Endevco model 3000 series cables	
Mounting torque	lbf-in (Nm)	18 (2)	18 (2)
Calibration			
Supplied:			
Charge frequency response	%	20 Hz to 4 kHz	20 Hz to 3 kHz
	dB	4 kHz thru resonance	3 kHz thru resonance
Charge sensitivity	pC/g		
Maximum transverse sensitivity	%		
Capacitance	pF		

Piezoelectric accelerometer | Model 7703A -200, -1000

Accessories			
Product	Description	7703A -200, -300, -1000	7703A -200-R, -1000-R
3090C-120	Cable assembly, for use up to 500°F, 10 ft	Included	Optional
2981-12	Mounting stud, 10-32 to 10-32	Included	Included
EHM464	Hex key wrench	Included	Optional
2981-3	Stud, 10-32 adapter	Optional	Optional
2981-4	Mounting stud, 10-32 to M5	Optional	Optional

Notes

1. Low-end response of the transducer is a function of its associated electronics. Models -200 and -1000 have case resonance at approximately 10 kHz.
2. Prolonged exposure at maximum temperature may decrease the return to room temperature resistance to as low as 25 MΩ but will not degrade the overall performance of the unit. All units are processed to initially meet 10 GΩ at room temperature.
3. Charge output is temperature compensated.
4. Short duration shock pulses, such as those generated by metal-to-metal impacts, may excite transducer resonance and cause linearity errors. See TP290 for more details.
5. Maintain high levels of precision and accuracy using Endevco's factory calibration services. Call Endevco's inside sales force at 1-800-982-6732 for recommended intervals, pricing and turn-around time for these services as well as for quotations on our standard products.

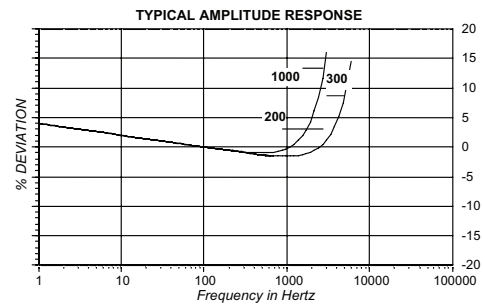
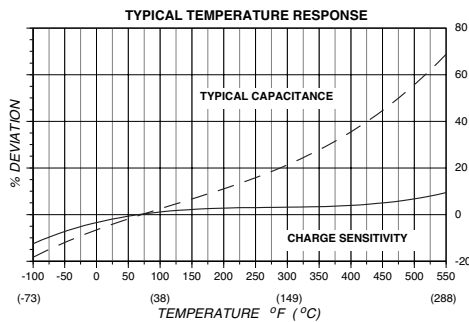

10869 NC Highway 903, Halifax, NC 27839 USA

endevco.com | sales@endevco.com | 866 363 3826

© 2022 PCB Piezotronics - all rights reserved. PCB Piezotronics is a wholly-owned subsidiary of Amphenol Corporation. Endevco is an assumed name of PCB Piezotronics of North Carolina, Inc., which is a wholly-owned subsidiary of PCB Piezotronics, Inc. Accumetrics, Inc. and The Modal Shop, Inc. are wholly-owned subsidiaries of PCB Piezotronics, Inc. IMI Sensors and Larson Davis are Divisions of PCB Piezotronics, Inc. Except for any third party marks for which attribution is provided herein, the company names and product names used in this document may be the registered trademarks or unregistered trademarks of PCB Piezotronics, Inc., PCB Piezotronics of North Carolina, Inc. (d/b/a Endevco), The Modal Shop, Inc. or Accumetrics, Inc. Detailed trademark ownership information is available at www.pcb.com/trademarkownership.

EDV-DS-7703A-200-1000-021023