

ENDEVCO High frequency IEPE accelerometer Model 7250B/7250BM1

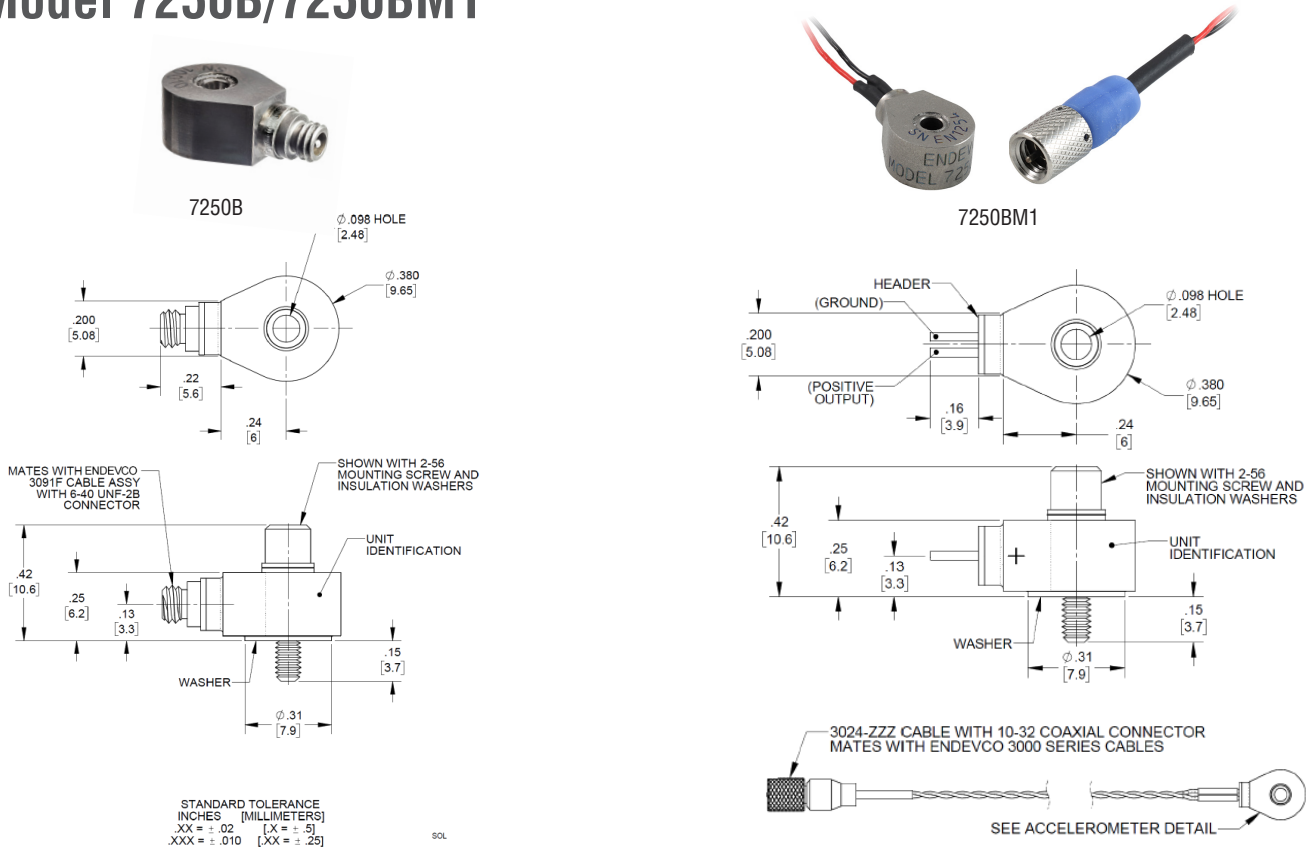

Key Features

- Excellent for very high frequency vibration measurements
- Hermetically sealed
- 360° cable orientation
- Light weight (1.9 gm)

Description

The Endevco® model 7250B is a subminiature, piezoelectric accelerometer with integral electronics, designed specifically for measuring vibration on small objects. The unit is hermetically sealed for use in extreme environments and to ensure long term stability. This accelerometer offers high resonance frequency and wide bandwidth, and its' light weight (1.9 gm) effectively eliminates mass loading effects.

The Model 7250B features an annular shear design, which exhibits excellent output sensitivity stability over time. Signal ground is connected to the outer case of the unit and, when used with the supplied isolated mounting screw/washer, it is electrically isolated from ground. The centrally located mounting bolt permits 360° cable orientation, however, the unit may also be adhesively mounted. A model number suffix indicates acceleration sensitivity in mV/g; i.e., 7250B-10 features output sensitivity of 10 mV/g. A special version, model 7250BM1, features two solderable terminals with a light weight cable attached and is terminated with a 10-32 connector.

ENDEVCO High frequency IEPE accelerometer | Model 7250B/7250BM1

The following performance specifications conform to ISA-RP-37.2 (1964) and are typical values, referenced at +75°F (+24°C) and 100 Hz, unless otherwise noted. Calibration data, traceable to National Institute of Standards and Technology (NIST), is supplied.

Specifications			
Dynamic characteristics	Units	-2	-10
Range	g	±2500	±500
Voltage sensitivity ±10%	mV/g	2	10
Frequency response		See typical curve, page 3	
Resonance frequency	kHz	85	
Amplitude response	Hz		
±1dB		3 to 20 000	
±3dB		1 to 40 000	
Temperature response		See typical curve	
Transverse sensitivity	%	≤ 5	
Amplitude linearity	%	1 to full scale	
Output characteristics			
Output polarity		Acceleration directed into base of unit produces positive output	
DC output bias voltage	Vdc	+11.0 to +14.0	
Output impedance	Ω	≤ 200	
Full scale output voltage	V	±5	
Resolution (1 Hz to 10 kHz)	equiv. g rms	0.0035	0.001
Grounding		Signal ground connected to case. Isolation achieved via isolated mounting washer and isolated screw	
Power requirement			
Supply voltage	Vdc	+24 to +28	+18 to +28
Supply current	mA	+2 to +20	
Warm-up time (to 10% of final bias level)	sec	< 3	
Environmental characteristics			
Temperature range		-67°F to +257°F (-55°C to +125°C)	
Humidity		Hermetically sealed	
Sinusoidal vibration limit	g pk	2000	
Shock limit [1]	g pk	10 000	
Base strain sensitivity			
Screw mounted	eq. g pk/μ strain	0.8	
Adhesive mounted	eq. g pk/μ strain	0.0004	
Thermal transient sensitivity	eq. g pk/°F (°C)	0.5 (0.9)	
Electromagnetic sensitivity	eq. g rms/gauss	0.2	
Acoustic sensitivity (at 155 dB SPL)	equiv. g	0.1	
Physical characteristics			
Dimensions		See outline drawing	
Weight			
Without mounting screw	gm (oz)	1.9 (0.067)	
With mounting screw	gm (oz)	2.4 (0.085)	
Case material		Titanium	
Connector			
7250B		6-40 receptacle	
7250BM1		Solder terminals with attached cable assembly terminated with a 10-32 connector	
Mounting torque	lbf-in (Nm)	5 (0.57)	
Calibration			
Supplied:			
Sensitivity	mV/g		
Maximum transverse sensitivity	%		
Frequency response	dB	20 Hz to 40 kHz	

Accessories				
Product	Description	7250B	7250BM1	7250B-R
3091F-120	Cable assembly, 6-40 to 10-32, 10ft	Included	Optional	Optional
3024-XXX	Cable assembly, pigtail to 10-32. -XXX defines cable length in inches. -120 is standard.	Optional	Attached	Optional
EHM178	Hex wrench	Included	Included	Optional
12746	Insulated mounting screw assembly	Included	Included	Included
EH96	Screw cap, hex socket, 2.56 x 3/8	Optional	Optional	Optional
EHN64	Nut, 2-56	Optional	Optional	Optional
EHW95	Washer	Optional	Optional	Optional
2950M18	Triaxial mounting block	Optional	Optional	Optional
133	Signal conditioner	Optional	Optional	Optional
4416C	Signal conditioner	Optional	Optional	Optional

Ordering information

- Maintain high levels of precision and accuracy using Endevco's factory calibration services. Call Endevco's inside sales force at 866-ENDEVCO for recommended intervals, pricing and turn-around time for these services as well as for quotations on our standard products.

Notes

- Short duration shock pulses, such as those generated by metal-to-metal impacts, may excite transducer resonance and cause linearity errors. Read TP290 for more details.
- Model number definitions:

